

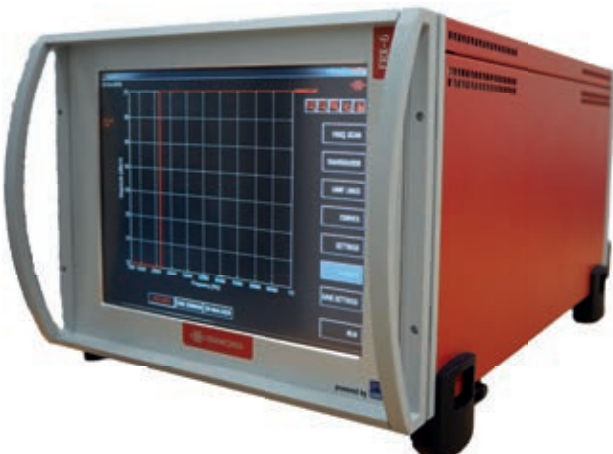

FRANKONIA

- ANECHOIC CHAMBERS, SHIELDED ROOMS & ACCESSORIES
- RADIATED IMMUNITY TEST SYSTEMS
- CONDUCTED RF IMMUNITY TESTING
- RF-POWER-AMPLIFIERS
- BROADBAND ANTENNAS
- EMISSION TEST SYSTEMS

MEASURING SYSTEMS FOR CONDUCTED AND RADIATED EMISSION TESTING



THE FRANKONIA GROUP



Frankonia Group

The FRANKONIA GROUP was founded in 1987 as a solution provider for EMC laboratories to meet the increasing demand for highly specialized testing environments for the electronic and automotive industry. With more than 25 years of experience to date, FRANKONIA maintains its leading position in EMC solutions worldwide. Without limitations in capabilities and resources, FRANKONIA develops future-oriented concepts for EMC laboratories, which guarantees an optimal use of resources as well as the best possible customized solutions.

- FRANKONIA demonstrates a global presence in cooperation, with a well-structured network of productions, representations and service units.
- FRANKONIA strives to be the preferred partner for customized and state-of-the-art solutions.
- FRANKONIA provides fundamental knowledge to operate as a complete solution provider.
- FRANKONIA implements innovative technologies to enhance the efficiency and improve the outcomes and quality along with customers' needs.



We are proud of our highly specialized team that is putting our customers' demands into practice. It is our philosophy to improve the products, to realize new ideas, and to complete our product range within our broad scope of business. The fact that FRANKONIA is able to offer complete solutions from the first sketch to the final handover makes FRANKONIA a unique and trustworthy partner worldwide.

Frankonia's authenticity

FRANKONIA stands for latest technologies, highest quality, innovative concepts and materials and reliable solutions. Due to its easy and efficient usability along with its time-saving configuration, Frankonia's Anechoic Chambers set new standards for innovative and complete EMC testing solutions and offer a real added value to our customers.

Frankonia solutions

FRANKONIA as a turnkey solution provider and manufacturer offers a complete range of anechoic chambers and RF-shielded enclosures, test equipment, instruments, software and accessories.



- 1 FRANKONIA GmbH
- 2 Frankonia EMC Test-Systems GmbH
- 3 FRANKONIA – POLAND Sp. z o.o.
- 4 Jiashan FRANKONIA EMC Co., Ltd.

EMISSION MEASURING SYSTEMS

Page

EMI TEST RECEIVER – ERX-6

4-9

EMI TEST RECEIVER – ERC-6

10-12

LINE IMPEDANCE STABILIZATION NETWORK's – LISN's

13-14

NEAR-FIELD PROBE SET – NFS-100

15

LARGE LOOP ANTENNA – LWL

16

ABSORBING CLAMP – ACF-01B

17



EMI TEST RECEIVER – ERX-6

Full compliant with CISPR 16-1-1, Ed.3.1 - 10 Hz to 6 GHz

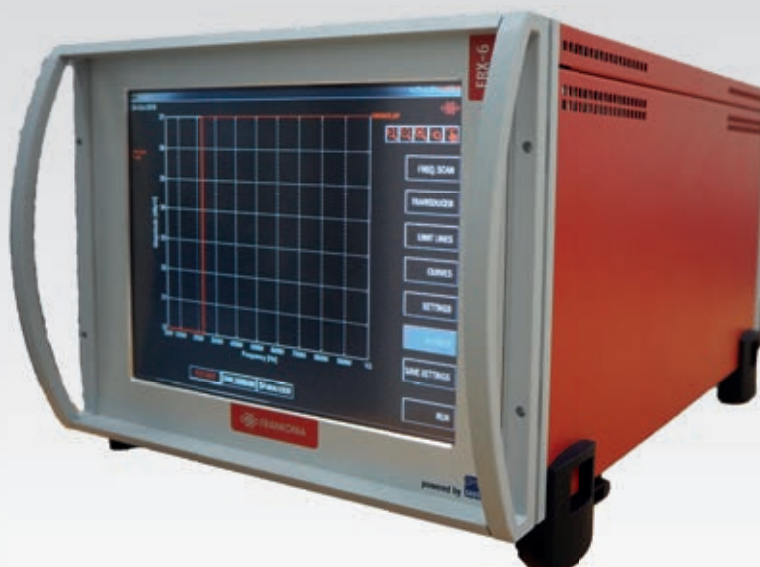

DESIGNED TO COMPETE WITH THE BEST!

Description:

The ERX-6 combines the advantages of a traditional EMI-receiver with the ultra-fast FFT-technology (time domain).

Further more it offers the full functionality of a realtime Spectrum Analyzer, which is very helpful to see immediate results of modifications on an EUT.

Optional available are a frequency extension up to 7 GHz, an integrated tracking generator (9 kHz - 6 GHz), a click analyzer function acc. to CISPR 14 and a battery pack for mobile operation.

Key Features:

- Frequency range 10 Hz to 6 GHz (7 GHz as Option)
- Traditional EMI-receiver mode acc. to CISPR 16-1
- Ultra-fast FFT-based (time domain) EMI-receiver-mode acc. to CISPR 16-1-1, Ed. 3.1
- Real-time Spectrum-Analyzer mode
- About 6000 times faster than traditional receivers
- Quasi-Peak, Peak, Average, RMS, RMS-AVG detectors
- Remote control of the receiver, antenna mast and turntable by using our „EM-LAB“ software
- Measurements acc. to CISPR, MIL, DO, VG, and ETSI-standards
- Excellent noise floor: 120 kHz (Band C/D), Typ. $-15 \text{ dB}\mu\text{V}$
1 MHz (Band E), Typ. $<- 3 \text{ dB}\mu\text{V}$

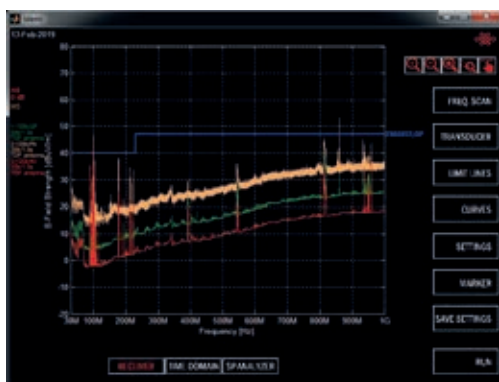

Test run with marker function

Available options:

- Frequency-extension up to 7 GHz
- Integrated tracking generator (9kHz - 6 GHz)
- Click analyzer function acc. to CISPR 14
- Battery pack for mobile operation

Rear view ERX-6



About FFT-based time domain measurements:

EMI measurements with traditional EMI-receivers in frequency domain are very time consuming. Final acceptance measurements can take up to several hours or even longer, because the EUT's may have a lot of different operation modes, which all has to be tested.

In the year 2010 the new FFT-based measuring instruments, working in time domain have been introduced by CISPR 16-1-1. A "revolution", because the new technology reduced hours of measuring time to a few seconds.

But it is not just a saving of measuring time and cost but also an acceleration of the developing work.

The benefits of FFT Technology can be used today for testing to all common standards (CISPR, EN/IEC, MIL-STD, ETSI).

Basically, we generally differentiate devices with hardware or only software based FFT technology.

Hardware based devices, like our ERX-6 offer the highest possible measuring speed, while software based solution, like our ERC-6 take some more time (but are still much faster than traditional receivers).

Our ERX-6 measures in 162 MHz frequency segments and outperforms comparable top-of-the-range devices many times over.

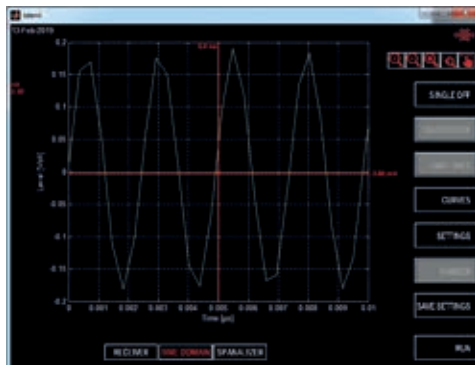

Oscilloscope mode

Principle of operation:

Measurements of emission are traditionally performed by measurement system operating in frequency domain. During the dwell time the input signal is observed at a single frequency and weighted with a detector e.g. the quasi-peak detector. During the complete dwell time the signal is processed via the analog and digital stages of an EMI receiver in a continuous way. Thus for the complete characterization of a device under test at a number of several thousand frequencies the measurement has to be repeated. For long dwell times which may be required by the time constants of the detector mode or due the discontinues disturbance of the device under test, the complete characterization of the device under test takes several hours.

The ERX-6 measurement system performs the signal processing in real-time without the digitized signal. The digitized signal is processed continuously. With current available digital hardware it is not possible to calculate the STFFT in real-time over a frequency range from DC – 1 GHz. Thus the frequency range of 1 GHz is subdivided into 8 bands that each are processed sequentially in real-time. All eight sub-bands are processed sequentially. Each sub-band is processed fully gapless in real-time by the ERX-6.

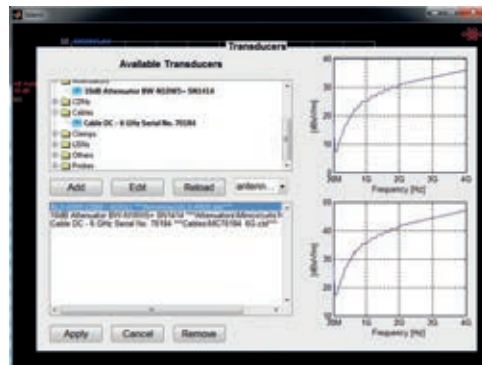

Correction factors

About the spectrum analyzer mode:

This mode provides a fast frequency domain continuous measurement with an IF filter range from 1 Hz up to 325 MHz. This function is available in the frequency-range from 10 Hz to 6 GHz.

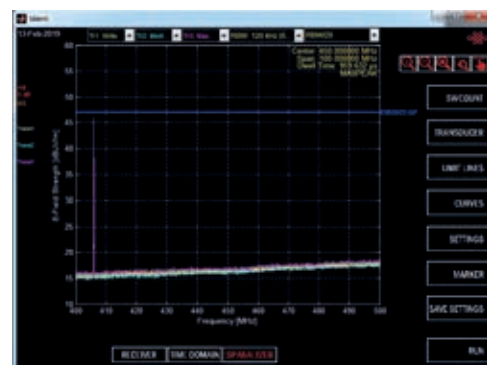

Spectrum analyzer mode

EMI TEST RECEIVER – ERX-6

Full compliant with CISPR 16-1-1, Ed.3 – 10 Hz to 6 GHz

Control software:

The scope of delivery already includes a comprehensive control software that can be operated either via the touch screen of the ERX-6 or by means of mouse and keyboard, that can be connected to the ERX-6.

No external PC is required!

The easy-to-use software allows you to perform all functions of the ERX-6, with easy switching between the functions in the main menu.

Furthermore this software offers a library for selecting the most common limit lines acc. to international standards, an input option for various correction factors (for e.g. antennas or RF-cables), the ability to create your own limit lines and a reporting function.

For the automation of measuring processes by means of turntable and antenna mast, we recommend our optionally available control software "EM-LAB" (please see also our separate brochure).

Library of limit lines



Technical Specifications ERX-6

Frequency range	10 Hz to 6 GHz (7 GHz optional)
Operating modes	<ul style="list-style-type: none">• EMI-receiver (traditional)• EMI-receiver (FFT-based measuring instrument)• Spectrum analyzer• Oscilloscope
Detectors	Quasi-Peak, Average, RMS, RMS-Average, CISPR-AVG, CISPR-RMS
Reference Oscillator	<ul style="list-style-type: none">• Reference oscillator OCXO• Aging < +/- 3.5 ppm / 15 years• Temperature drift (0 – 60° C) < +/- 1 x 10e-8• SSB phase noise (1 Hz BW): 1 Hz -95 dBc/Hz (12.8 MHz) 10 Hz -120 dBc/Hz 100 Hz -140 dBc/Hz 1 kHz -145 dBc/Hz• Frequency resolution 0.01 Hz
Spectral purity	<ul style="list-style-type: none">• SSB phase noise frequency = 500 MHz, carrier offset• 100 Hz < -100 dBc (1 Hz)• 1 kHz < -107 dBc (1 Hz)• 10 kHz < -101 dBc (1 Hz)• 100 kHz < -126 dBc (1 Hz)• 1 MHz < -146 dBc (1 Hz)• 10 MHz < -150 dBc (1 Hz) (nom.)• Residual FM frequency = 500 MHz, RBW = 1 kHz, Sweep time = 100 ms < 3 Hz (nom.)

EMI-receiver

Frequency readout (Analyzer mode)

- Marker resolution 0.5 Hz
- Uncertainty $\pm(\text{marker frequency} \times \text{reference accuracy} + 10\% \times \text{resolution bandwidth} + \frac{1}{2}(\text{span}/(\text{sweep points} - 1)) + 0.5 \text{ Hz})$
- Spectrum analyzer 1 to 8 000 000
- EMI measurement 1 to 8 000 000
- Marker tuning frequency step size marker step size = sweep points span/(sweep points – 1)
- Marker step size = standard span / (default sweep points – 1)
- Frequency counter resolution 0.001 Hz
- Count accuracy $\pm (\text{frequency} \times \text{reference accuracy} + \frac{1}{2}(\text{last digit}))$
- Display range for frequency axis 0 Hz, 10 Hz to max. frequency
- Resolution 0.1 Hz
- Max. span deviation $\pm 0.1\%$

Receiver scan

- Scan scan with max. 100 subranges with different settings
- Scan modes normal scan, FFT-based measuring instrument according to CISPR 16-1-1
- Measurement time superhet scan, per frequency 1 μs to >100 s
- Measurement time FFT-based measuring instrument, per frequency 1 μs to >100 s
- Number of trace points up to 8 000 000
- Frequency step size normal scan min. 1 Hz
- Frequency step size FFT-based measuring instrument min. 1 Hz

EMI-receiver FFT-based Measuring Instrument

Frequency segment processed in parallel	RBW = 10 Hz	0.06 MHz
	RBW = 100 Hz	0.6 MHz
	RBW = 200 Hz	1.1 MHz
	RBW = 1 kHz	5.7 MHz
	RBW = 9 kHz	57 MHz
	RBW = 10 kHz	57 MHz
	RBW = 120 kHz	225 MHz
	RBW = 100 kHz	225 MHz
	RBW = 1 MHz	225 MHz
	RBW = 10 MHz	225 MHz

Scanning speed (Receiver mode) typ.

- Band A, Quasi-peak, dwell time 1 s : 2 s
- Band B, Quasi-peak, dwell time 1 s : 2 s
- Band C/D Quasi-peak, dwell time 1 s : 30 s
- Band E (1 GHz – 6 GHz), dwell time 100 ms : 2 s

FFT-Overlapping Factor

- according to CISPR 16-1-1 and CISPR 16-3
- Overlapping factor typ > 95% 1

EMI TEST RECEIVER – ERX-6

Full compliant with CISPR 16-1-1, Ed.3 – 10 Hz to 6 GHz

Spectrum Analyzer

Spectrum Analyzer

- Sweep time range span = 0 Hz, 1 μ s to 16000 s
- Span \geq 10 Hz, swept 1 μ s to 16000 s
- Span \geq 10 Hz, FFT based measuring instrument 1 μ s to 16000 s
- Sweep time accuracy span = 0 Hz \pm 0.1 % (nom.)
- Span \geq 10 Hz, swept \pm 1 % (nom.)

IF Bandwidths

- 3dB bandwidth: 1 Hz – 30 MHz
- 1, 2, 3, 5 steps
- Small step size (145 steps) for channel measurements
- 6dB bandwidths CISPR: 200 Hz, 9 kHz, 120 kHz, 1 MHz
- 6dB bandwidths MIL/D0: 10 Hz, 100 Hz, 1 kHz, 100 kHz, 1 MHz

Video filter

- 0.1 Hz – 10 MHz + 3*RBW
- 1, 2, 3, 5 steps

Detectors (Video filter off / 3 RBW)

- MaxPeak, MinPeak, Sample
- Dynamic requirements according to CISPR 16-1-1 (Peak, AVG)

FFT-based measuring instrument acc. to CISPR 16-1-1, MIL461 and other EMC standards (time domain scan)

Preselection and Preamplifier structure

Multiple paths with fixed filters

Analog Preselection

10 Hz – 9 kHz	450 MHz – 675 MHz
9 kHz – 150 kHz	675 MHz – 900 MHz
150 kHz – 30 MHz	900 MHz – 1 GHz
225 MHz – 250 MHz	1 GHz – 3 GHz
30 MHz – 225 MHz	3 GHz – 6 GHz

Preamplifier

- Located between preselection and ADC & mixer
- Individual pre-amps for different frequency ranges
- Gain: Typ. 20 dB, full overrange detection and auto attenuation
- Noise figure: Typ 3.5 dB, Frequency range: 10 Hz – 6 GHz

Digital Preselection

0 MHz – 225 MHz
225 MHz – 450 MHz
450 MHz – 675 MHz
675 MHz – 900 MHz
900 MHz – 1 GHz

Low noise Amplifier

30 MHz – 6 GHz (7 GHz with Option ERX-FE7), Noise Figure < 4dB

General data	
Level	<ul style="list-style-type: none"> • Display range displayed noise floor up to +30 dBm • Maximum DC input level, pulse 6 V (0dB Att) • RF-CW signal 120 dBV
Intermodulation	<ul style="list-style-type: none"> • 1dB Compression Point of Mixer <ul style="list-style-type: none"> f < 1 GHz f > 1 GHz • Third order Intercept Point (TOI) <ul style="list-style-type: none"> 10 Hz – 6 GHz Typ. > 20dBm • Second Harmonic Intercept Point (SHI) <ul style="list-style-type: none"> 10 Hz – 6 GHz Typ. > 55dBm
Displayed Average Noise Level RF attenuation 0dB, normalized to 1 Hz RBW, mean marker (typ.)	<ul style="list-style-type: none"> • 9 kHz – 150 kHz: 130 dBm • 150 kHz – 1 MHz: 154 dBm • 1 MHz – 30 MHz: 161 dBm • 30 MHz – 1000 MHz: 163 dBm (LNA off) 169 dBm (LNA on) • 1000 MHz – 6 GHz: 164 dmb (LNA off) 170 dBm (LNA on)
Noise Indication RF attenuation 0dB, RBW acc. to CISPR 16-1-1, mean marker (typ.)	<ul style="list-style-type: none"> • 9 kHz – 150 kHz: < 0 dBuV • 150 kHz – 1 MHz: < -5 dBuV • 1 MHz – 30 MHz: < -18 dBuV • 30 MHz – 1000 MHz: < -6 dBuV (LNA off) <12 dBuV (LNA on) • 1000 MHz – 6 GHz: < 4 dBuV (LNA off) 3 dBuV (LNA on)
CISPR Indication Range	<ul style="list-style-type: none"> • 6 dB margin to noise floor over complete amplitude range according to CISPR 16-1-1 Ed. 3.1 • Quasi-peak indication according to CISPR 16-1-1: All pulse repetition frequencies • Peak, Average, CISPR-AVG indication according to CISPR 16-1-1 in all modes • CISPR-RMS indication according to CISPR 16-1-1 • Maximum deviation for sinusoidal signals according to CISPR 16-1-1: 2dB (9 kHz – 6 GHz)
Absolute level uncertainty	<ul style="list-style-type: none"> • Signal level : 40 – 60 dBuV (15 MHz) < 0.3 dB ($\sigma = 0.1$) • Frequency response (9 kHz – 6 GHz) < 0.5 dB ($\sigma = 0.15$) • Attenuator switching uncertainty (15 MHz) < 0.2 dB ($\sigma = 0.15$) • Total measurement uncertainty CW signal, S/N > 20 dB 95 % confidence level: 0.5 dB
Spurious Response	<ul style="list-style-type: none"> • Residual spurious response RF attenuation = 0 dB • $f \leq 1$ MHz < -107 dBm • $f \leq 1$ MHz < -117 dBm • $f > 1$ MHz < -112 dBm • Image frequency < -80 dBc (nom.)
Attenuator	<ul style="list-style-type: none"> • 0 – 50 dB, 10 dB steps
Inport Ports RF Input	<ul style="list-style-type: none"> • N type connector, 50 Ohm • 0 dB attenuator: VSWR < 2.0 (9 kHz – 1 GHz) • 10 dB attenuator: VSWR < 3.0 (1 GHz – 6 GHz)
Remote Control	Remote control command set according to SCPI standard
Interfaces	Ethernet/LAN, USB, VGA, HDMI, Audio
Display, User Interface	Resolution 800 x 600 Pixel, 8,4" , TrueColor (16.78 Mio. colors), Touchscreen
PC	<ul style="list-style-type: none"> • Mobile Multi Core processor, 8 GByte RAM, >250 GByte Solid State Disc, Winows® 10, 64Bit
Power Supply	+11 V .. +14 V DC, 230 V +/-20 % 50 Hz or 110 V +/- 10% 60 Hz Max. power consumption approx. 60 W
Weight	approx. 8 kg

EMI TEST RECEIVER – ERC-6

Full compliant with CISPR 16-1-1, Ed.3.1 – 9 kHz to 6 GHz



Description

Although the „ERC-6“ is the less expensive little brother of our flagship „ERX-6“, it is more than worth to have an intensive look on it. With the ERC-6 only properties, that are not required for full-compliance EMI measurements according to CISPR 16-1, have been reduced or omitted. The ERC-6 is therefore a good alternative to the „high-end-devices“ for many users, such as in-house developing departments. The Receiver can either be operated via the integrated touch-PC with 10“ monitor or by external software. The external software enables fully automated measurements including automatic control of antenna mast and turntable. Also the fast, FFT-based (time domain) measuring mode is already included in the ERC-6.

Key Features

- Frequency-range 9 kHz – 6 GHz
- Traditional EMI-receiver mode according to CISPR 16-1
- Fast, FFT-based (time domain) EMI-receiver mode acc. to CISPR 16-1-1, Ed.3.1
- Integrated touch-PC, with 10“- monitor
- Integrated 20 dB (15 dB > 1 GHz) pre-amplifier
- Full-compliant according to CISPR 16-1
- Peak, Quasi-Peak, Average, RMS, CISPR-Average detectors available (RMS-average optional)

About FFT-based time domain measurements:

EMI measurements with traditional EMI-receivers in frequency domain are very time consuming. Final acceptance measurements can take up to several hours or even longer, because the EUT's may have a lot of different operation modes, which all has to be tested.

In the year 2010 the new FFT-based measuring instruments, working in time domain have been introduced by CISPR 16-1-1.

A “revolution”, because the new technology reduced hours of measuring time to a few seconds.

But it is not just a saving of measuring time and cost but also an acceleration of the developing work.

The benefits of FFT Technology can be used today for testing to all common standards (CISPR, EN/IEC, MIL-STD, ETSI).

Basically, we generally differentiate devices with hardware or only software based FFT technology.

Hardware based devices, like our ERX-6 offer the highest possible measuring speed, while software based solution, like our ERC-6 take some more time (but are still much faster than traditional receivers).



rear view

EMI TEST RECEIVER – ERC-6

Full compliant with CISPR 16-1-1, Ed.3.1 – 9 kHz to 6 GHz

Technical data	9 kHz – 30 MHz Input	30 MHz – 6 GHz Input
Frequency range	9 kHz to 30 MHz	30 MHz to 6 GHz
Resolution	0.1 Hz	100 Hz
Reference frequency	< 1 ppm	< 2 ppm
RF input	Z _{in} 50 Ω, BNC fem.	Z _{in} 50 Ω, N fem.
VSWR		
10 dB RF att.	< 1.2	< 1.2 ; < 2 above 1 GHz
0 dB RF att.	< 1.6	< 2 ; < 3 above 3 GHz
Attenuator	0dB to 35 dB (5 dB steps)	0 dB to 55 dB (5dB steps)
Pulse limiter	Built-in (selectable)	n.a.
Preamplifier gain	20 dB (selectable)	20 dB, 15 dB above 1 GHz
Max. input level (without equipment)	137 dBμV (1 W) (1)	
Sinewave AC voltage Pulse spectral density	97 dBμV / MHz (2)	
Preselector		
Frequency ranges	9 kHz to 150 kHz (six bandpass filters) 150 kHz to 5.67 MHz 5.67 MHz to 11.19 MHz 11.19 MHz to 16.71 MHz 16.71 MHz to 22.23 MHz 22.23 MHz to 30 MHz	30 MHz to 72 MHz (four tracking filters and two bandpass filters) 72 MHz to 173 MHz 173 MHz to 416 MHz 416 MHz to 1 GHz 1 GHz to 3 GHz 3 GHz to 6 GHz
IF bandwidth	1, 3, 10, 30, 100, 300 kHz (6 dB) 200 Hz and 9 kHz (CISPR 16-1-1) 10, 100 Hz – 1, 10 kHz (MIL STD-461) (option)	3, 10, 30, 100, 300 kHz (6 dB) 120 kHz (CISPR 16-1-1) 1 MHz (CISPR 16-1-1)
Detectors	Peak, Quasi-peak, Average, RMS, CISPR-Average, (RMS-average option)	
Noise level (Preselector ON) (Preamplifier OFF) (Hold time 1000 ms)	9 to 150 kHz < -14 dBuV (AV) (200 Hz BW) 0.15 to 30 MHz < 0 dBuV (AV) (9 kHz BW)	30 to 300 MHz < 7 dBuV (AV) (120 kHz BW) 300 to 1000 MHz < 10 dBuV (AV) (120 kHz BW) 1000 to 4000 MHz < 13 dBuV (AV) (120 kHz BW) 4000 to 6000 MHz < 18 dBuV (AV) (120 kHz BW)

EMI TEST RECEIVER – ERC-6

Full compliant with CISPR 16-1-1, Ed.3.1 – 9 kHz to 6 GHz

Technical data	9 kHz – 30 MHz Input	30 MHz – 6 GHz Input
Noise level (Preselector ON) (Preamplifier ON) (Hold time 1000 ms)	9 to 150 kHz < -24 dBuV (QP) (200 Hz BW) 0.15 to 30 MHz < -10 dBuV (AV) (9 kHz BW)	30 to 300 MHz < -8 dBuV (AV) (120 kHz BW) 300 to 1000 MHz < -5 dBuV (AV) (120 kHz BW) 1000 to 4000 MHz < -1 dBuV (AV) (120 kHz BW) 4000 to 6000 MHz < +3 dBuV (AV) (120 kHz BW)
Scan time SWEEP MODE (Fill CISPR: preselector ON, QP detector)	A band (9 to 150 kHz) < 8s (hold time 1 s) 200 Hz RBW B band (150 kHz to 30 MHz) < 20 s (hold time 1 s) 9 kHz RBW	C+D band (30 MHz to 1 GHz) < 2.2s (H.T. lowest) 120 kHz RBW ⁽³⁾ < 76s (H.T. 100ms) < 746s (H.T. 1s) E band (1 to 6 GHz) 1 MHz RBW ⁽³⁾ < 6.7 s (H.T. lowest) < 800s (H.T. 100ms)
ANALYZER MODE (preselector OFF, Peak detector)	A band (9 to 150 kHz) < 0.5s (hold time lowest) 200 Hz RBW B band (150 kHz to 30 MHz) 9 kHz RBW < 1 s (hold time lowest)	C+D band (30 MHz to 1 GHz) 120 kHz RBW < 1.1 s (H.T. Lowest) 1 MHz RBW < 0.7 s (H.T. Lowest) E band (1 to 6 GHz) 1 MHz RBW < 5.7 s (H.T. Lowest)
Spurious response (Preselector ON / Preamp OFF) (AVG Ht 1 s) ⁽⁴⁾	< -10 dBuV, < 0 dBuV above 150 kHz	< 6 dBuV, < 15 dBuV above 2 GHz
Measurement accuracy S/N > 20 dB	± 0.0 dB	30 to 1000 MHz ± 1.0 dB 1 to 3 GHz ± 1.5 dB 3 to 6 GHz ± 2.0 dB
Demodulation	AM and FM (through internal speaker and 3.5mm earphones jack)	
I/O Interface	USB; RS-232; User port for accessories	
Operating temperature	0° C to 40° C	
Power supply	100 to 240 Vac – 50/60 Hz – 25 W	
Dimensions	Standard EIA Rack unit (2RU) – 482mm (10" w) x 95mm (3.7" h) x 485mm (19.1" d)	
Weight	7 kg	

⁽¹⁾ Min att ≥ 10 dB

⁽²⁾ Min att ≥ 10 dB, preselector ON

⁽³⁾ Smart detector function available

⁽⁴⁾ RBW 10 kHz prescan Ht lowest, then AVG 1s on the 10 worst peaks

LINE IMPEDANCE STABILIZATION NETWORK's – LISN's

acc. to CISPR-16, VDE 0876 and FCC part 15



1 LISN C4-32
2 LISN C2-16

Introduction

The objective of EMI conducted tests is to define the amplitude of current I_c and Voltage V_c emission from the Device Under Test (DUT) onto the power mains. The mains lines themselves do not allow for reliable EMI measurements since their impedance is subject to marked variations that generates different test results at different test sites. Frankonia's artificial mains network C2-16 are LISN's, used for RFI measurements on AC single-phase (C4-32 = AC three-phase), power supplied electric and electronic equipment, drawing up to 16 (32) Amps, which corresponds to the most common applications. The C2-16 is a two line (the C4-32 a three line) V-network with an equivalent circuit of $50 \text{ ohm} // (5 \text{ ohm} + 50 \mu\text{H})$, fully compliant with CISPR publ. 16, VDE 0876 and FCC part 15 regulation. The Frankonia C2-16 / C4-32 are suited to perform measurements on conducted interference in the frequency range from 9 kHz to 30 MHz.

The main functions performed by the artificial mains network are:

- terminate the DUT with a standardized impedance against reference ground
- supply power to the DUT;
- insulate the test circuits against external interference coming, for example, from AC-voltage network
- route the EMI (Electro Magnetic Interference) of the DUT to the receiver

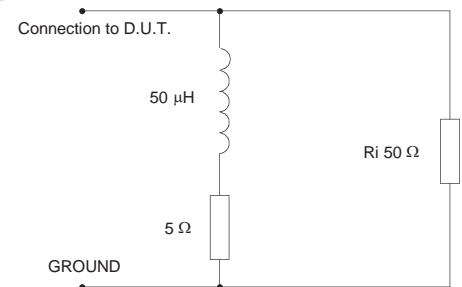

R_i = input impedance of the RFI

Ferrite-cores coils are used in the low-pass filter. Saturation effects have been avoided designing a ferrite-core that is able to withstand a 50% increase of the I_{max} value without any saturation. Frankonia C2-16 is provided with standard SCHUKO power socket 16 Amps. to connect test item, but other connector types are available on request.

Technical data	C2-16	C4-32
Frequency range	9 kHz to 30 MHz	9 kHz to 30 MHz
Continuous rated output current	16A SCHUKO plug	IEC plug: 32A, SCHUKO plug: 16A
Max. permissible operating voltages (L/N) (L/PE)	250 VAC 350VDC	Single-phase (L/N) (L/PE) (N/PE): 230VAC 325 VDC Three-phase (L/PE) (N/PE): 230VAC 325VDC (L/L) (L/N): 400VAC 565VDC
AC supply frequency range	DC - 60 Hz	DC - 60 Hz
Equivalent circuit	$50 \text{ Ohm} // (5 \text{ Ohm} + 50 \mu\text{H})$	$50 \text{ Ohm} // (5 \text{ Ohm} + 50 \mu\text{H})$
RF output	BNC female	BNC female
Power supply connector	SCHUKO connector	32A IEC connector and 16A SCHUKO
Rated temperatur	-10° to + 45° C	-10° to + 40° C
Storage temperatur	-25° to + 75° C	-25° to + 75° C
Overall dimensions mm (W x H x D)	230 x 105 x 285	342 x 254 x 510
Weight	5.5 kg	16.5 kg

LINE IMPEDANCE STABILIZATION NETWORK's – LISN-KFZ & LISN-MIL

acc. to automotive standards and MIL-STD

1 LISN-KFZ

2 LISN-MIL



Description LISN-KFZ

The main application of the unsymmetrical single path AMN (artificial mains network) LISN-KFZ is the measurement of interference voltage in vehicles, aircrafts and ships in the HF-VHF range 0.1 – 150 MHz. The LISN can also be used for bulk current injection (BCI) testing or for transient measurements according to ISO 7637-2. The impedance characteristic is realized according to CISPR 16/25 and MILSTD-461F ($5 \mu\text{H} + 1 \Omega$) || 50Ω . With the optionally available external capacitor CAP 10 it can be used for DO-160 and DEF-STAN59 as well. The continuous current rating is 70 A, for short time more than 100 A are possible. The EuT is connected to the wing terminals at the front panel. The mains terminals are on the backside.

Description LISN-MIL

This Line-Impedance Stabilisation Network (LISN) is designed according to MIL461E or MIL-461F respectively (Measurement of Electromagnetic Interference Characteristics). This corresponds to older versions of CISPR 16-1-2 Chapter 4.2 for a single path with $50 \mu\text{H} + 5 \text{ Ohm}$ || 50 Ohm . In opposite to newer CISPR versions MIL has no requirements regarding the phase of the impedance or the decoupling

Technical data LISN-KFZ

Frequency range	100 kHz – 150 MHz
Max. cont. current	70 A
Max. current (limited time)	100 A
Max. voltage DC	500 V
Max. voltage 50/60 Hz	250 V
Max. voltage 400 Hz	130 V
Impedance	$(5 \mu\text{H} + 1 \text{ fi}) \parallel 50 \text{ fi} \pm 10 \%$
Resistance of coil	< 5 mfi
Impedance at 50 Hz	4.2 mfi
Impedance at 400 Hz	13 mfi
Weight	650g
Connector EuT	7mm wing terminals
RF output	BNC (optional N)
Dimensions incl. connectors W x H x D	160mm x 210mm x 165mm

Technical data LISN-MIL

Frequency range	(9) 150 kHz – 100 MHz
Max. cont. current	70 A
Max. current (limited time)	100 A
Max. voltage DC	250 V
Max. voltage (AC 50/60 Hz)	250 V
Max. voltage (AC 400 Hz)	140 V
Impedance	$(50\mu\text{H}+5\Omega)\parallel 50\Omega (+/- 20 \%)$
DC-Resistance mains-EuT	ca. 10 mΩ
Weight	4.5kg
Dimensions (W x H x D)	220mm x 220mm x 260mm
EuT Connectors	Wing terminals
Supply Connectors	Wing terminals
Connector for receiver	BNC female 50Ω

Circuit diagrams (schematic)

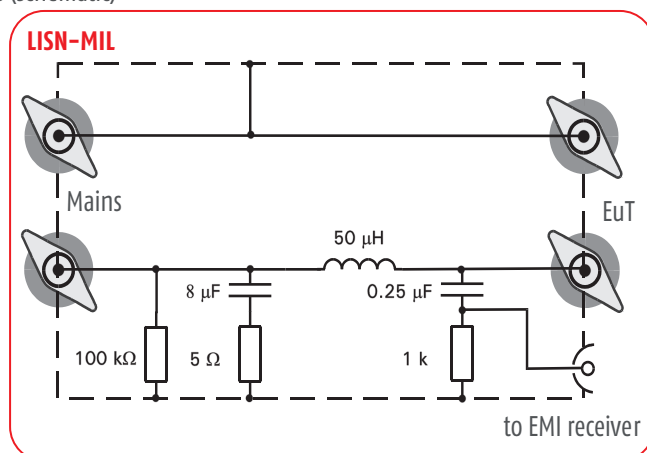
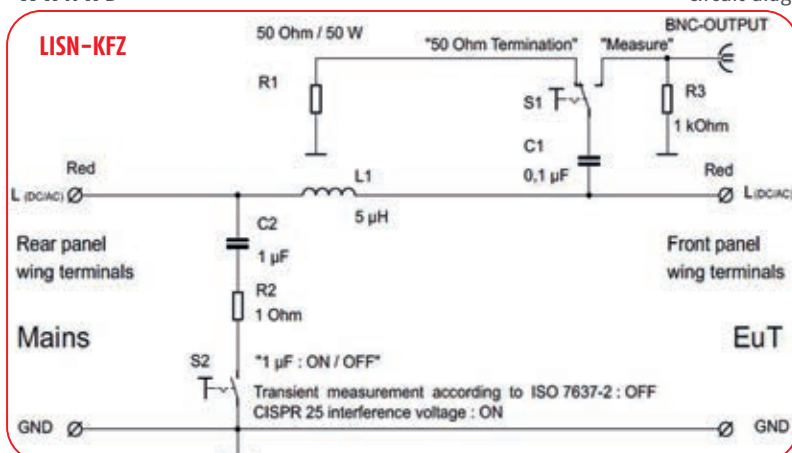



Technical data

Length (overall)	E: 180mm H: 183mm
Diameter (outer)	H: 69mm
Isolation voltage	1 kV
Connection	BNC
Frequency range	E: 80 MHz to 500 MHz H: 10 MHz to 500 MHz
Output impedance	50 Ω (nom)

NFS-100 includes:

- E probe
- H probe
- BNC adaptor
- Sensitivity plots
- Hard carry case

Key Features:

- Ideal for location of sources
- Quickly identifies emission frequencies
- Checking of screening effectiveness
- Quick check of production samples
- Passive probes for high dynamic range
- Good rejection of background
- Fully Insulated, moulded body for safety
- Can be used with any spectrum analyser or receiver
- Direct connection for standard BNC cables. Kit includes BNC adaptor which enables direct connection to pre-amp or similar

LARGE LOOP ANTENNA – LWL

acc. to CISPR-15, EN55015 (LUMINAIRES)



Description

The LWL is a fully compliant, calibrated 2 m large loop antenna that complies with standard CISPR-15 / EN55015 section 7.2 and annex B. The calibrated frequency range is 9 kHz to 30 MHz. Each antenna is supplied with antenna factor data. It can be used with any EMC receiver or spectrum analyser. The performance of the loops is matched to the 'ideal' loop as shown in EN55015 fig B4 using the prescribed test set-up. The LWL is a complete 3-axis antenna with a switching unit to select each loop in turn. The loops are 2 metre in diameter with the lowest point 0.5 metres above ground and are fitted with specially designed current transducers in fully screened housings.

The main framework is wood with 25 mm diameter plastic tubing for the loops.

Key features

- Fully compliant with CISPR-15 / EN55015 (Luminaires)
- Complete 3-axis design
- Simple and fast installation and easy collapsible to sub units
- Calibrated
- Useable with any EMI receiver or spectrum analyzer

Technical data

Loops	Triple independent loops, 2m diameter
Sensors	Matched inductively coupled
Selector	Loop selection by patch panel switch
Output	50 Ω BNC
Calibration	Each axis tested and correction data included with antenna
Antenna factor	Matched to EN55015, figure B4
Power read	None
Dimensions (H x W x W)	2.6m x 2.1m x 2.1m

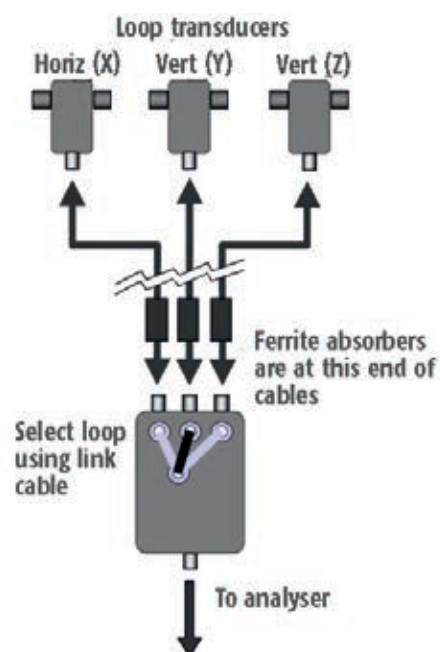

LWL-C optional available:

If on-site calibration is deemed necessary, the LWL-C allows the calibration loop to be used on all three axes and rotated within each as required by the standards.



Description

The absorbing clamp is used for measurements according to CISPR 13 / 14 / EN 55014-1, etc. In the measurement setup, the power cord of the equipment under test has to be extended to a length of 6m. The cable is fed through the clamp's opening and placed on a nonmetallic table. It is connected to a power supply. The measuring receiver is connected to the 50 Ohm output of the clamp. The clamp, which is moveable on wheels, is driven along the cable to the power supply. If decoupling of the clamp is too weak, an optional decoupling clamp could be used on the power line close to the power plug. The detected maximum resonance is the requested measuring value. As the clamp is constructed to have 17dB coupling attenuation, the receiver voltage (dB μ V) is equal to the interference power (dBpW). A 6dB attenuator at the clamp's output increases the measuring accuracy as described in CISPR 16-1-3 and the measuring result has to be corrected according to the attenuator's value.

Technical data

Frequency range	30 MHz to 1000 MHz
Typical insertion loss acc. to CISPR-16	17 dB \pm 4 dB
Decoupling (typ.)	1 MHz - 30MHz: 5dB - 20dB, >20dB from 30MHz to 1 GHz
Impedance	50 Ω
Max. input current (peak)	30 A
Input power (peak)	5 W
Max. cable diameter	20mm
Dimensions (B x H x D) in mm	600 x 105 x 80
Weight	6.5kg

EMI power dBpW = Measured Voltage dB μ V + (Correction Clamp dB incl. optional Attenuator)



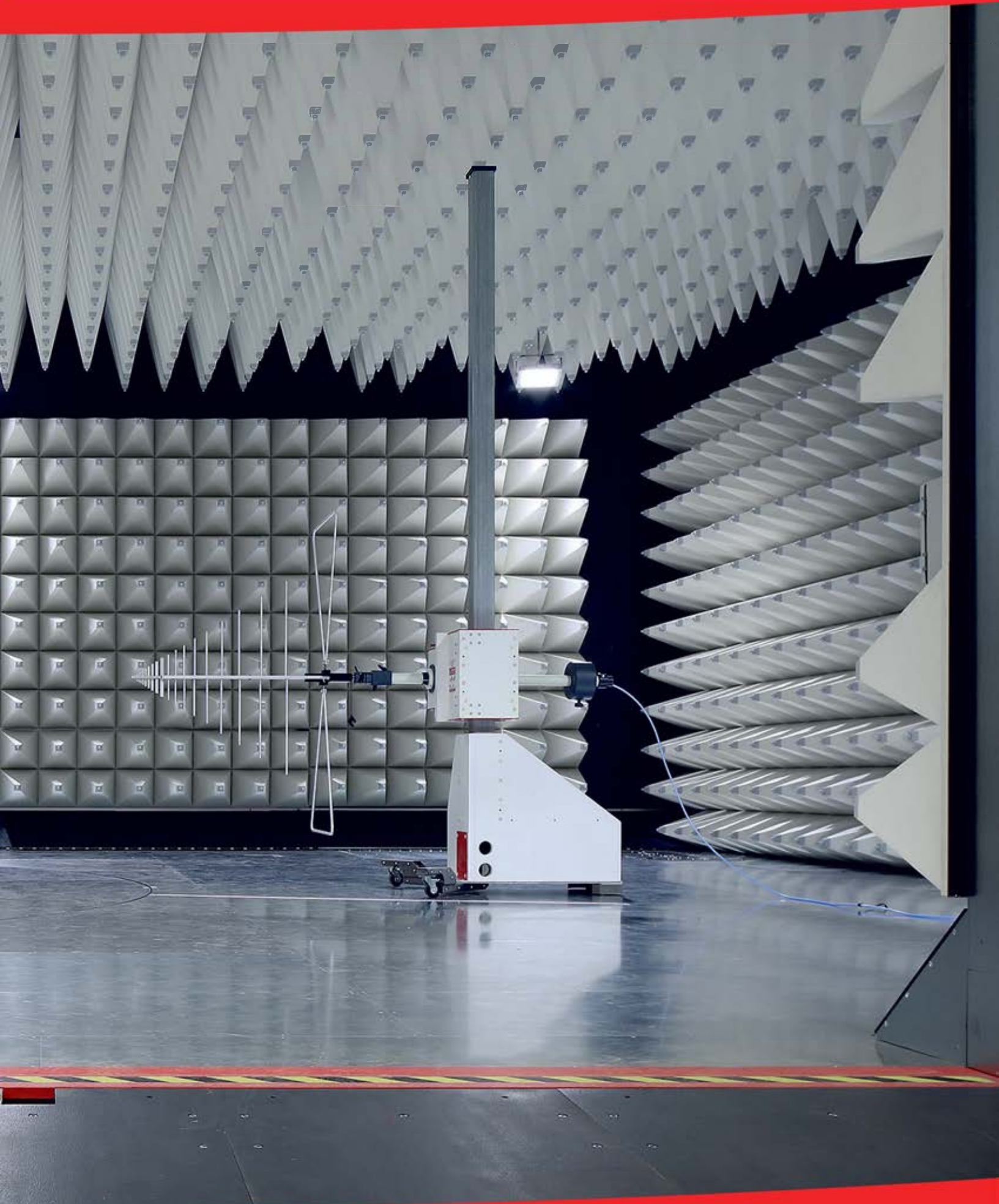



AP-FLYER Sp. z o.o.
Żegańska St.
04-713 Warsaw, POLAND

Phone: +48 22 613 0487
Mail: emc@ap-flyer.pl



www.ap-flyer.pl



FRANKONIA