



FRANKONIA

- ANECHOIC CHAMBERS, SHIELDED ROOMS & ACCESSORIES
- RADIATED IMMUNITY TEST SYSTEMS
- CONDUCTED RF IMMUNITY TEST SYSTEMS
- RF-POWER-AMPLIFIERS
- BROADBAND ANTENNAS
- EMISSION TEST SYSTEMS

CONDUCTED RF IMMUNITY TEST SYSTEMS

acc. to IEC / EN 61000-4-6, NAMUR

and

BCI testing acc. to ISO 11452-4, MIL-STD 461, CS 114
D0-160 (conducted susceptibility)



THE FRANKONIA GROUP



Frankonia Group

The FRANKONIA GROUP was founded in 1987 as a solution provider for EMC laboratories to meet the increasing demand for highly specialized testing environments for the electronic and automotive industry. With more than 25 years of experience to date, FRANKONIA maintains its leading position in EMC solutions worldwide. Without limitations in capabilities and resources, FRANKONIA develops future-oriented concepts for EMC laboratories, which guarantees an optimal use of resources as well as the best possible customized solutions.

- FRANKONIA demonstrates a global presence in cooperation, with a well-structured network of productions, representations and service units.
- FRANKONIA strives to be the preferred partner for customized and state-of-the-art solutions.
- FRANKONIA provides fundamental knowledge to operate as a complete solution provider.
- FRANKONIA implements innovative technologies to enhance the efficiency and improve the outcomes and quality along with customers' needs.



We are proud of our highly specialized team that is putting our customers' demands into practice. It is our philosophy to improve the products, to realize new ideas, and to complete our product range within our broad scope of business. The fact that FRANKONIA is able to offer complete solutions from the first sketch to the final handover makes FRANKONIA a unique and trustworthy partner worldwide.

Frankonia's authenticity

FRANKONIA stands for latest technologies, highest quality, innovative concepts and materials and reliable solutions. Due to its easy and efficient usability along with its time-saving configuration, Frankonia's Anechoic Chambers set new standards for innovative and complete EMC testing solutions and offer a real added value to our customers.

Frankonia solutions

FRANKONIA as a turnkey solution provider and manufacturer offers a complete range of anechoic chambers and RF-shielded enclosures, test equipment, instruments, software and accessories.



- 1 FRANKONIA GmbH
- 2 Frankonia EMC Test-Systems GmbH
- 3 FRANKONIA - POLAND Sp. z o.o.
- 4 FRANKONIA Huize Co., Ltd.
- 5 Jiashan FRANKONIA EMC Co., Ltd.



RF Immunity Testing	Page
Conducted immunity test system - CIT-100	4-6
Conducted immunity test system - CIT-1000	7-10
Coupling / Decoupling network - CDN	11-18
EM-Coupling clamp - EMCL	19
EM-Decoupling clamp - ABCL-20	20
BCI-clamp / current monitoring clamp	21-22
Control software - Helia	23-24
Setup for CDN-calibration	25
Setup for testing with CDNs	26
Setup for calibration with EM-clamp	27
Setup for testing with EM-clamp	28
Setup for BCI-calibration	29
Setup for BCI-testing	30

CONDUCTED IMMUNITY TEST SYSTEM – CIT-100

acc. to IEC/EN 61000-4-6, ISO 11452-4, MIL-STD



- Conducted RF Immunity Testing
- BCI-Testing

Description

The CIT-100 is a complete test system for conducted RF-immunity testing and BCI-testing acc. to IEC/EN 61000-4-6, ISO 11452-4, MIL-STD 461, CS114 and similar standards.

The system consists of a built-in

- Signal generator, 4kHz - 1.2 GHz
- RF-Power-Amplifier, max 4kHz - 400 MHz, 25 / 75 W
- 3-Channel RF-Power-Meter to measure the test level as well as forward & reverse power, 4kHz - 1.2 GHz
- Directional Coupler
- Comfortable control software

As a „stand-alone“ test system the CIT-100 is convincing by its easy and comfortable handling and the excellent cost-performance ratio.

We also offer the full range of coupling/decoupling networks (CDN's), EM-coupling clamp, BCI- and current clamps.

Special Features:

- Conducted RF immunity tests acc. to IEC/EN61000-4-6 and BCI tests acc. to ISO 11452-4 and MIL-STD 461, CS 114
- Signalgenerator, RF-power amplifier, RF-power meter and directional coupler in one 19"-case
- All built in instruments can also be used separately, via existing input / output connector. Hence, the Signal-generator and the RF-power-meter can also be used for radiated immunity tests acc. IEC/EN 61000-4-3. Furthermore an additional external RF-Power-amplifier could be connected to the CIT-100 for this purpose.
- Stand-alone operation possible with optional available netbook
- Control-software included
- Most important parameters are shown on an integrated display
- Automatic EUT-monitoring
- Operation via USB port of a PC or Notebook
- Complete range of CDNs and EM-clamps available

Also available as CIT-1000 with built-in touch-screen and control PC for independent stand-alone use.

CONDUCTED IMMUNITY TEST SYTEM – CIT-100

acc. to IEC/EN 61000-4-6, ISO 11452-4, MIL-STD

Technical specifications	
RF-Generator	
Two switchable outputs (Only one can be used simultaneously)	2 x SMA
Frequency range	4 kHz to 1.2 GHz
Frequency resolution	1 Hz
Output level range	0 to -63 dBm
Output level resolution	0.1 dB
Harmonics	< 30 dBc
Spurious	< 45 dBc
Amplitude mod. (internal)	0 - 100%, resolution 1%
Amplitude mod. (external)	0-100%, max. Amplitude 1V=100%, BNC jack
Pulse modulation (internal)	5-95%, resolution 1%
Pulse modulation (external)	DC...1MHz, 3,3/5V CMOS/TTL, BNC jack
LF-Generator (modulation)	
Connector	BNC jack
Frequency range	1 Hz to 100 kHz
Frequency resolution	0.1 Hz
Signal	Sine wave / square wave / triangular
Amplitude	0...1 V

Technical specifications	
RF-Voltmeter 1 (test-level)	
Connector	BNC jack
Frequency range	4 kHz to 1.2 GHz
Measuring range	-40 to +30 dBm
RF-Voltmeter 2 + 3 (forward and reverse power)	
Connector	2 x SMA
Frequency range	4 kHz to 1.2 GHz
Measuring range	-40 to +33 dBm + directional coupler typ. 40 dB
EUT-Monitor input	
Input voltage	0-10 V
Resolution	2.5 mV
Input impedance	100 k
EUT-failed input	
Input signal	3.3/5V CMOS/TTL level
Detection Mode	Status or edge controlled
Temperature measurement	10 to 100 °C (1039-1385Ω) resolution < 1 °C (PT1000)
SCPI interfaces	
USB 2.0	USB-B
LAN, 100 Mbit	RJ45
GPIB (optional)	Centronics
Digital I/Os	
Out	4 Bit Digital out, 5V CMOS/TTL
In	4 Bit Digital in, 5V CMOS/TTL
Interlock	
Closes at	R < 1 k Ω

Technical specifications	CIT-100 / 25	CIT-100 / 75 MIL	CIT-100 / 75
RF-Power Amplifier (TYPE)	25 W	75 W MIL	75 W
Frequency range	100kHz-250MHz	(4) 10kHz-250 (400) MHz	100kHz-400MHz
Output Power:			
Nominal	25 W	75 W 10W from 4 kHz - 10 kHz min. 20 W from 250 MHz - 400 MHz	75 W
Linear @ 1dB compression	20 W	50 W	50 W
Gain	46dB nominal	51dB nominal	51dB nominal
Flatness		± 1.5 dB maximum	
Input power for rated input		1 mW / 0 dBm	
Input / output impedance		50 Ω	
Input VSWR		1.5:1 max	
Harmonic distortion	<- 20 dBc @ 20 W	<- 20 dBc @ 50 W	<- 20 dBc @ 50 W
Noise figure	typ. 5 dB	typ. 7 dB	typ. 7 dB
Spurious output		<- 75 dBc @ 10 W	

CONDUCTED IMMUNITY TEST SYSTEM – CIT-100

acc. to IEC/EN 61000-4-6, ISO 11452-4, MIL-STD

Features:

Internal RF-Power Amplifier

Several amplifier modules are available. Highest output power can be 75 W over the specified frequency range. The amplifier input can be accessed via the back panel of the CIT-100, so that the amplifier can also be used with any external generator. 25 W and 75 W amplifiers are available as standard.

Internal RF-Voltmeter

Accurate measurements of RF signals from -40 dBm up to +30 dBm are done by the internal 3-channel RF-voltmeter which can be accessed (for separate use) via a BNC connector. One channel is used to measure the test level and two channels to measure the forward and reverse power via the built-in directional coupler.

Internal RF-Signal Generator

As the internal generator generates its output signal without any internal mixing components, low harmonics and spurious frequencies are assured.

Amplitude Modulation

Frequencies generated by the generator can also be modulated with a LF signal. Modulation frequencies may vary from 1 Hz up to 100 kHz, modulation levels are available from 0 % to 100 %.

User defined signals

External signals (e.g. EUT-fail or external instruments) can be connected and monitored using the application software.

Setup:

The CIT-100 is a PC-controlled test equipment. It can be operated by any commercial IBM compatible PC (Microsoft® Windows software) via USB port. All settings of the equipment, e.g. start frequency, stop frequency, step width, test voltage etc. are made by means of the control software which is also included in the delivery. The three functional units RF-signal generator, RF-power amplifier and RF-voltmeter are set automatically by the software, depending on the pre-set test parameters.

Each component, however, may also be called and operated as separate measuring and testing equipment. This means: using the CIT-100 as testing system, you have three full, additional "single units" at your disposal, for which separate inputs and outputs are available as BNC connections. Due to the computer-aided control of the CIT-100, any modifications which may become necessary, for example, due to the revision of standards, may be performed without problems and without having to manipulate the hardware of the equipment.

Quick overview of the different versions:

Type	CIT-100 / 25	CIT-100 / 75 MIL	CIT-100 / 75
Signalgenerator	4 kHz to 1.2 GHz		
RF-Power-Amplifier	25 W 100 kHz - 250 MHz	75 W from 10kHz - 250MHz 10 W from 4 kHz - 100 kHz min. 20 W from 250 MHz - 400 MHz	75 W 100 kHz - 400 MHz
RF-Power-Meter (3-channel)	4 kHz to 1.2 GHz		
Directional coupler	4 kHz to 1.2 GHz		

CONDUCTED IMMUNITY TEST SYSTEM – CIT-1000

acc. to IEC/EN 61000-4-6, ISO 11452-4, MIL-STD



Description:

The CIT-1000 is a complete test system for conducted RF-immunity tests acc. to IEC/EN 61000-4-6 and BCI-testing acc. to ISO 11452-4, MIL-STD 461 CS 114 and similar standards., like our well known type CIT-10. Signal generator, Power-Amplifier, RF-Power-meter, directional coupler and control software are all together in one box.

With the CIT-1000 our product-line has been extended by another, even more powerful and flexible product.

In addition to the CIT-10 it offers the following additional benefits:

- Frequency extension of the signal generator, directional coupler and RF-Voltmeter up to 1.2000 MHz, additional possibility for use for radiated immunity testing acc. to IEC/EN 61000-4-3
- Possibility to connect an external power amplifier for radiated immunity testing acc. to IEC/EN 61000-4-3
- Stand-alone operation via integrated touch-screen PC
- Integrated directional coupler + 3 pcs. RF-Voltmeter (1 pc. for test level, 2 pcs. for forward and reverse power)
- Great selection of RF-power-amplifier-modules for almost any application
- Temperature-measuring input for control and display of the BCI-clamp temperature
- Frequency extension for MIL-STD 461 testing down to 4 kHz, by means of the external device „CIT-4K“, with a 250 W power-amplifier
- Operation via „Helia“-device software (included) or via optional available „PROVE-EMC“ system software

In addition, all integrated devices, like Signal Generator, RF-Voltmeter and Power-Amplifier, can also be used individually via separate input/output connectors.

CONDUCTED IMMUNITY TEST SYSTEM – CIT-1000

acc. to IEC/EN 61000-4-6, ISO 11452-4, MIL-STD

Technical specifications

RF-Generator

Two switchable outputs (only one can be used simultaneously)	2 x SMA
Frequency range	4 kHz to 1.2 GHz
Frequency resolution	1 Hz
Output level range	0 to -63 dBm
Output level resolution	0.1 dB
Harmonics	< 30 dBc
Spurious	< 45 dBc
Amplitude modulation (internal)	0 to 100%, resolution 1%
Amplitude modulation (external)	0 to 100% , max. Amplitude 1V = 100%, BNC jack
Pulse modulation (internal)	5 to 95%, resolution 1%
Pulse modulation (external)	DC...1MHz, 3,3/5V CMOS/TTL, BNC jack

LF-Generator (modulation)

Connector	BNC jack
Frequency range	1 Hz to 100 kHz
Frequency resolution	0.1 Hz
Signal	Sine wave / square wave / triangular
Amplitude	0...1 V

RF-Voltmeter 1 (test level)

Connector	BNC jack
Frequency range	4 kHz to 1.2 GHz
Measuring range	-40 to +30 dBm

RF-voltmeter 2+3 (forward and reverse power)

Connector	2 x SMA
Frequency range	4 kHz to 1.2 GHz
Measuring range	-40 to + 33 dBm + directional coupler typ. 40 dB

EUT-Monitor input

input voltage	0 to 10 V DC
resolution	2.5 mV
Input impedance	100 k

EUT-failed input

Input signal	3,3/5V CMOS/TTL level
Detection mode	status or edge controlled
Temperature measurement	10 to 100 °C (1039 to 1385 Ω) resolution < 1 °C (PT 1000)

SCPI interfaces

USB 2.0	USB-B
LAN, 100 Mbit	RJ45
GPIB (optional)	Centronics

Digital I/Os

Out	4 Bit Digital out, 5 V CMOS/TTL
In	4 Bit Digital in, 5 V CMOS/TTL

Interlock

Closes at	R < 1 kΩ
-----------	----------

CONDUCTED IMMUNITY TEST SYSTEM – CIT-1000

acc. to IEC/EN 61000-4-6, ISO 11452-4, MIL-STD

Technical specifications

RF-Power Amplifier (TYPE)	25 W	75 W Namur	75 W	180 W
Frequency range	100kHz-250MHz	(4) 10kHz-250 (400) MHz	100kHz-400MHz	1MHz-400MHz
Output Power :				
Nominal	25W	75W 10W from 4 kHz - 10 kHz min. 20W from 250MHz - 400MHz	75W	180W
Linear @ 1dB compression	20W	50W	50W	100W
Gain	46dB nominal	51dB nominal	51dB nominal	56dB nominal
Flatness	±1.5 dB maximum			
Input power for rated output	1 mW / 0 dBm			
Input / output impedance	50 Ω			
Input VSWR	1.5:1 max			
Harmonic distortion	<-20 dBc @ 20W	<-20 dBc @ 50W	<-20dBc @ 50W	<-20 dBc @ 100W
Noise figure	typ. 5 dB	typ. 7 dB	typ. 7 dB	
Spurious output	<-75 dBc @ 10 W			

rear view

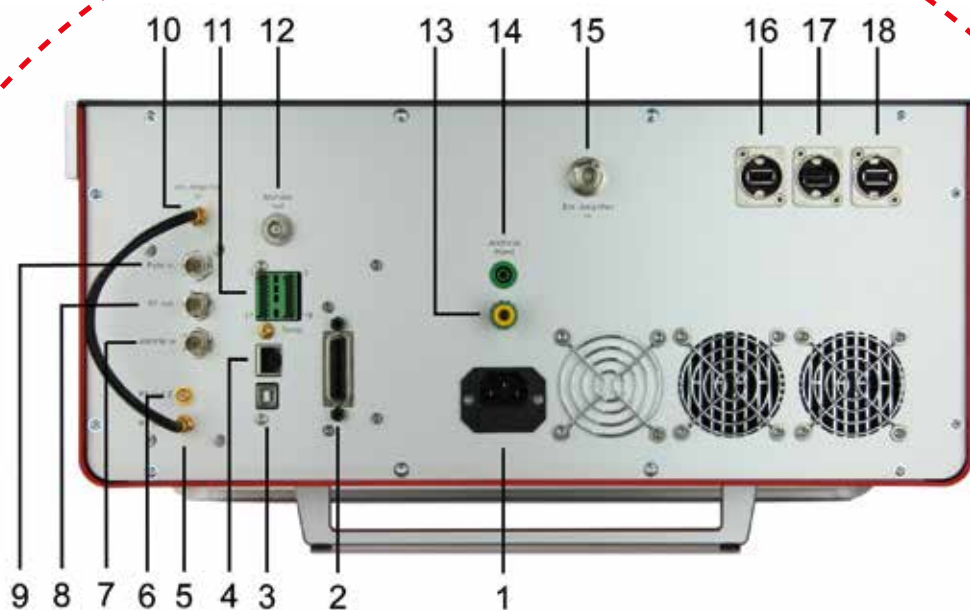

- | | |
|---------------------------------------|------------------------------|
| (1) Mains connector | (2) GPIB |
| (3) PC (USB) | (4) LAN (RJ45) |
| (5) RF-Generator Out 1 (SMA) | (6) RF-Generator Out 2 (SMA) |
| (7) AM external IN (BNC) | (8) Audio Freq Out (BNC) |
| (9) Pulse Modulation In (BNC) | (10) Amplifier In |
| (11) Socket Connector | (12) Monitor Out |
| (13) Artificial Hand | (14) Ground Connection |
| (15) Input for External Amplifier (N) | (16) USB 1 |
| (17) USB 2 | (18) External display (HDMI) |

CONDUCTED IMMUNITY TEST SYSTEM – CIT-1000

acc. to IEC/EN 61000-4-6, ISO 11452-4, MIL-STD



CIT-4K

Frequency extension for MIL-STD 461 testing down to 4 kHz, type CIT-4K

- Frequency extension down to 4 kHz for the CIT-1000
- Optimal addition to the 180 W-amplifier from 1–400 MHz
- Optimal cooling concept by temperature controlled fans
- Short-circuit protection
- Overload protection
- Linear MOSFET amplifier-technology
- Class A/B amplifier
- Suitable for all types of modulation
- Interlock input
- Remote-control via USB and LAN

Technical specifications

Frequency-range: 4 kHz to 1 MHz

Power output: 250 W

Input connector: SMA, 50 Ω

Input power for nominal output power: 1 mW / 0 dBm

Output connector: N, 50 Ω

Description

CDN-AF type networks are required for coupling and decoupling disturbing signals to an unshielded cable with non-balanced lines.

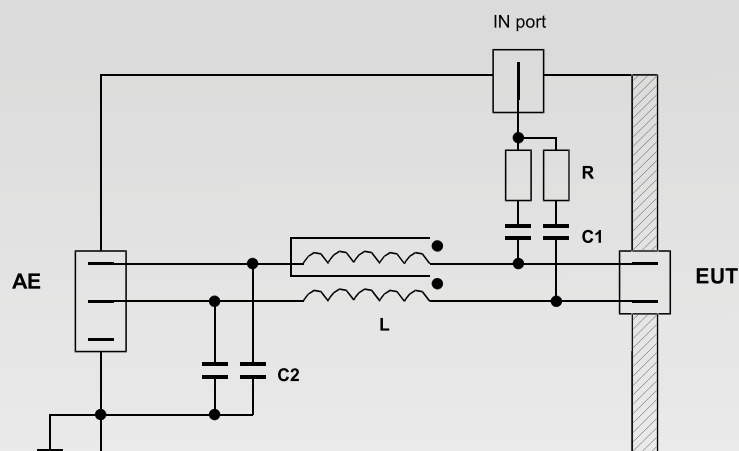

Simplified diagram for the circuit of CDN-AF2



Type CDN-AF2/3/4/5/8

RF-in		EUT / AE
Frequency range (RF In)	(10 kHz) 150 kHz – 80 MHz / 230 MHz (300 MHz)	Maximum Input Voltage AC 100 V
Power Rating (RF In)	6 W (continuous)	Maximum Input Voltage DC 150 V
Decoupling attenuation (RF In – AE)	> 20 dB (150 kHz – 230 MHz)	Current Rating (AE – EUT) 1 A
	> 40 dB (1 MHz – 100 MHz)	Insertion loss (AE – EUT) < 1dB (DC – 100 kHz)
Insertion loss (RF In – EUT)	10 dB ± 1 dB (150 kHz – 80 MHz);	Connectors Terminal block, safety banana jack
	10 dB + 3 dB (150 kHz – 230 MHz)	
Connector	BNC	Mechanical Data
		Dimensions (B x H x T) 160mm x 84.5mm x 240mm

Ordering Informations

CDN-AF2, terminal block 2 pole, 150 kHz – 300 MHz	CDN-AF4-10k-MC, 4mm safety banana jack, 10 kHz – 80 MHz
CDN-AF2-MC, 4mm safety banana jack, 150 kHz – 300 MHz	Calibration adapter, CDN-AF4 / T4
CDN-AF2-10k-MC 4mm safety banana jack, 10 kHz – 230 MHz	CDN-AF5-MC, 4mm safety banana jack, 150 kHz – 230 MHz
Calibration adapter, CDN-AF2 / T2	CDN-AF5-10k-MC, 4mm safety banana jack, 10 kHz – 230 MHz
CDN-AF3, terminal block 3 pole, 150 kHz – 230 MHz	CDN-AF8, terminal block 8 pole, 150 kHz – 230 MHz
CDN-AF3-MC, 4mm safety banana jack, 150 kHz – 230 MHz	Calibration adapter, CDN-AF8
CDN-AF3-10k-MC 4mm safety banana jack, 10 kHz – 230 MHz	CDN-AF8-10k-Sub-D, 9-pin Sub-D, 10 kHz – 230 MHz
CDN-AF4, terminal block 4 pole, 150 kHz – 230 MHz	Calibration adapter, CDN-AF8-Sub-D, CDN-CAN-L5
CDN-AF4-MC, 4mm safety banana jack, 150 kHz – 230 MHz	CDN-AF9, terminal block 9 pole, 150 kHz – 230 MHz
Calibration adapter, CDN-AF9	

COUPLING / DECOUPLING NETWORKS – CDN M1 / 2 / 3 / 4 / 5

acc. to IEC/EN 61000-4-6



Description

CDN M-types are used for all power supply lines. Numerous types are available for EUT voltages of up to 1000 VAC and EUT currents of up to 100 A.

Type	CDN-M1/2/3/4/5	CDN-M2/3/4/5/-HV	CDN-M2/3/4/5-63A/100A
RF-in			
Frequency range (RF In)	(10 kHz) 150 kHz – 80 MHz / 230 MHz (300 MHz)		
Power Rating (RF In)	6 W (continuous)		
Decoupling attenuation (RF In – AE)	> 30 dB (150 kHz – 80 MHz) 10 dB + 5 dB (80 MHz – 230 MHz)	> 30 dB (150 kHz – 80 MHz) > 15 dB (80 MHz – 230 MHz)	
Insertion loss (RF In – EUT)	10 dB +2/-1 dB (150 kHz – 80 MHz) 10 dB +2/-1 dB (150 kHz – 80 MHz)	10 dB +2/-1 dB (150 kHz – 80 MHz) 10 dB + 5 dB (80 MHz – 230 MHz)	
Connector	BNC		
EUT / AE			
Maximum Input Voltage AC (Line-PE)	280 V	600 V (1000 V VHV-Types)	600 V
Maximum Input Voltage AC (Line-Line)	485 V	1000 V (1700 V VHV-Types)	1000 V
Maximum Input Voltage DC	500 V	1000 V	6000 V
Current Rating (AE – EUT)	16 A / 32 A / 63 A / 100 A; (M1 / M2+3 IPE <0.5 A)		
Insertion loss (AE – EUT)	< 1dB (DC – 100 kHz)		
Connectors	4 mm safety banana jack	6 mm round connectors for current > 32 A Adequate safety test leads are included	
Mechanical Data			
Dimensions (B x H x T)	160mm x 84.5mm x 240 mm	200mm x 122.5 mm x 400 mm	

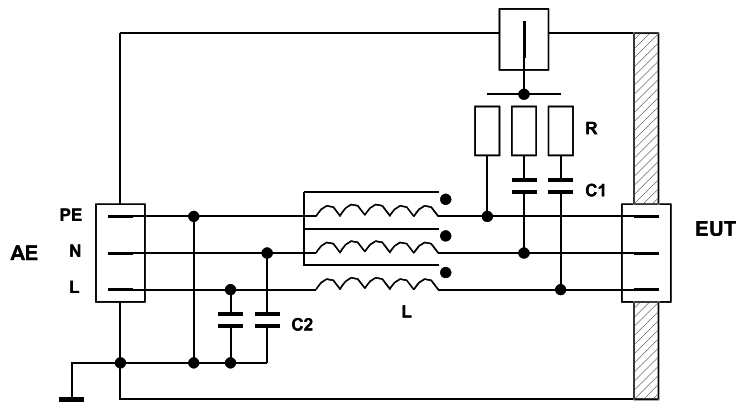

Simplified diagram for the circuit of CDN-M3 used with unscreened supply (mains) lines

Ordering Informations

CDN-M1, 4mm safety banana jack, 150 kHz – 230 MHz	CDN-L1, 4mm safety banana jack, 150 kHz – 230 MHz
CDN-M1-10k, 4mm safety banana jack, 10 kHz – 230 MHz	CDN-M2, 4mm safety banana jack, 150 kHz – 300 MHz
CDN-M2-10k, 4mm safety banana jack, 10 kHz – 230 MHz	CDN-M2-32A, 4mm safety banana jack, 150 kHz – 230 MHz
CDN-M2-32A-HV, 4mm safety banana jack, 150 kHz – 230 MHz	CDN-M2-63A-HV, 6mm round connector, 150 kHz – 80 MHz
CDN-M2-100A-HV, 6mm round connector, 150 kHz – 80 MHz	CDN-M2+3, 4mm safety banana jack, 150 kHz – 300 MHz
CDN-M2+3-10k, 4mm safety banana jack, 10 kHz – 230 MHz	CDN-M2+3-32A, 4mm safety banana jack, 150 kHz – 230 MHz
CDN-M3, 4mm safety banana jack, 150 kHz – 300 MHz	CDN-M3-L, L1/L2/L3, 4mm safety banana jack, 150 kHz – 230 MHz
CDN-M3-32A, 4mm safety banana jack, 150 kHz – 230 MHz	CDN-M3-L1L2N-32A, L1/L2/N, 4 mm safety banana jack, 150 kHz – 230 MHz
CDN-M3-L-32A, L1/L2/L3, 4mm safety banana jack, 150 kHz – 230 MHz	CDN-M3-L-32A-10k, L1/L2/L3, 4mm safety banana jack, 10 kHz – 230 MHz
CDN-M3-32A-HV, 4mm safety banana jack, 150 kHz – 80 MHz	CDN-M3-L-32A-HV, 4mm safety banana jack, 150 kHz – 80 MHz
CDN-M4-32A-10k, 4mm safety banana jack, 10 kHz – 230 MHz	CDN-M4-32A-HV, 4mm safety banana jack, 150 kHz – 80 MHz
Calibration adapter, CDN-M1 / -M2 / -M3	CDN-M4-N-32A-HV, 4mm safety banana jack, 150 kHz – 80 MHz
CDN-M4-63A-HV, 6mm round connector, 150 kHz – 80 MHz	CDN-M4-N-63A-HV, L1/L2/L3/N, 6mm round connector, 150 kHz – 80 MHz
CDN-M4-100A-HV, 6mm round connector, 150 kHz – 80 MHz	CDN-M4-N-100A-HV, L1/L2/L3/N, 6mm round connector, 150 kHz – 80 MHz
CDN-M5, 4mm safety banana jack, 150 kHz – 230 MHz	CDN-M5-32A, 4mm safety banana jack, 150 kHz – 230 MHz
CDN-M5-32A-HV, 4mm safety banana jack, 150 kHz – 80 MHz	CDN-M5-32A-VHV, 4mm safety banana jack, 150 kHz – 80 MHz
CDN-M5-63A-HV, 6mm round connector, 150 kHz – 80 MHz	CDN-M5-100A-HV, 6mm round connector, 150 kHz – 80 MHz
Calibration adapter, CDN-M4 / -M5	Calibration adapter "Delta", CDN-M4 / -M5
Calibration adapter, CDN-M4-63A / -M5-63A	Calibration adapter, CDN-M4-100A / -M5-100A

Mounting bracket for calibration adapter incl. 50/150 Ohm adapter and 50 Ohm termination

Description

For coupling and decoupling of interference signals on screened lines CDN S-Types are used. Despite the variety of connectors the interference signal is in all cases coupled to the cable shield via a 100 Ω resistor. A device for direct coupling is also available (without decoupling network).

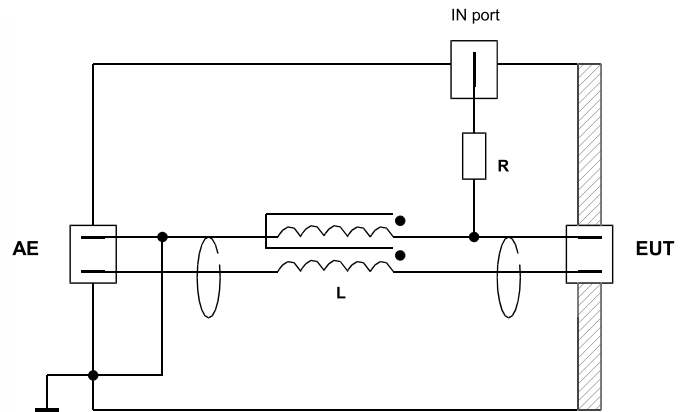

Simplified diagram for the circuit of CDN-S1

Type	CDN-S1	CDN-S2	CDN-S4	CDN-S8	CDN-S9	CDN-S15	CDN-S25
RF-in							
Frequency range (RF In)	150 kHz – 230 MHz						
Power Rating (RF In)	6 W (continuous)						
Decoupling attenuation (RF In – AE)	> 35 dB (150 kHz – 80 MHz) > 30 dB (80 MHz – 230 MHz)						
Insertion loss (RF In – EUT)	10 dB ± 1 dB (150 kHz – 80 MHz); 10 dB + 3 dB (80 MHz – 230 MHz)						
Connector	BNC						
EUT / AE							
Maximum Input Voltage AC	150 V					600 V (1000 V VHV-Types)	600 V
Maximum Input Voltage DC	200 V					1000 V (1700 V VHV-Types)	1000 V
Current Rating (AE – EUT)	1.5 A					1000 V	6000 V
Insertion loss (AE – EUT)	< 1dB (0 – 10 MHz) < 10 dB (10 MHz – 500 MHz)						
Connectors	BNC	XLR	5-pin XLR	8-pin Mini-DIN	9-pin Sub-D	15-pin Sub-D	25-pin Sub-D
Mechanical Data							
Dimensions (B x H x T)	160mm x 84.5mm x 240 mm						

Type	USB-C	USB-P	HDMI	Firewire	USB-3.0	RJ45-S
RF-in						
Frequency range (RF In)	(10 kHz) 150 kHz – 230 MHz					
Power Rating (RF In)	6 W (continuous)					
Decoupling attenuation (RF In – AE)	> 50 dB (150 kHz – 80 MHz) > 25 dB (80 MHz – 230 MHz)				> 30 dB (150 kHz – 230 MHz) > 15 dB (80 MHz – 230 MHz)	
Insertion loss (RF In – EUT)	10 dB ± 1 dB (150 kHz – 80 MHz) 10 dB + 3 dB (80 MHz – 230 MHz)				10 dB ± 1 dB (150 kHz – 80 MHz) 10 dB + 3 dB (80 MHz – 230 MHz)	
Connector	BNC					
EUT / AE						
Maximum Input Voltage AC	100 V					
Maximum Input Voltage DC	150 V					
Current Rating (AE – EUT)	0.5 A					
Current Rating (AE – EUT)	0.5 A				0.9 A	1.0 A
Insertion loss (AE – EUT)	< 1dB (DC – 10 MHz) < 10 dB (10 MHz – 500 MHz)				< 0.3 dB (DC – 10 MHz) < 1 dB (10 MHz – 100 MHz) < 3 dB (100 MHz – 500 MHz)	
Connectors	EUT: USB-B AE: USB-A	EUT: USB-A AE: USB-B	HDMI 19-pol	Firewire 6-pol	USB-3.0	Shielded RJ45 jack
Mechanical Data						
Dimensions (B x H x T)	160mm x 84.5mm x 240 mm					

Direct injection device

100 Ω connector for RF disturbances 150 kHz – 230 MHz

The disturbing signal coming from the test generator is injected on to screened and coaxial cables via a 100 Ω resistor (even if the shield is ungrounded or grounded at one end only). In between the auxiliary equipment (AE) and the injection point, a decoupling circuit shall be inserted as close as possible to the injection point. To increase decoupling and to stabilize the circuit, a ground connection shall be made from the screen of the direct injection device's input port to the ground reference plane.

Electrical Data	
Frequency range (RF In)	150 kHz – 230 MHz
Common mode impedance (IN/OUT)	100 Ω
Power Rating (RF In)	6 W (continuous)
Connector Out	Alligator clip; max. cable diameter 30 mm
Connector In	BNC

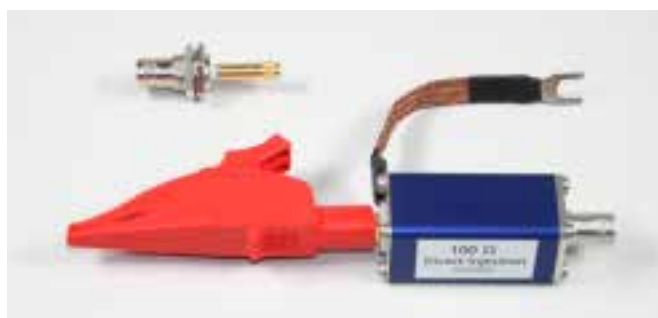

Ordering Informations

CDN-S1, BNC, 150 kHz - 230 MHz	CDN-S1-10k, BNC, 10 kHz - 230 MHz
CDN-S1-75Ω, BNC, 150 kHz - 230 MHz	Calibration adapter, CDN-S1
CDN-S2, XLR, 150 kHz - 230 MHz	CDN-S2-10k, XLR, 10 kHz - 230 MHz
Calibration adapter, CDN-S2	CDN-S3-10k, XLR, 10 kHz - 230 MHz
Calibration adapter, CDN-S3	CDN-S4, 5-pin XLR, 150 kHz - 230 MHz
Calibration adapter, CDN-S4	CDN-S8, 8-pin Mini-DIN, 150 kHz - 230 MHz
Calibration adapter, CDN-S8	CDN-S9, 9-pin Sub-D, 150 kHz - 230 MHz
CDN-S9-10k, 9-pin Sub-D, 10 kHz - 230 MHz	Calibration adapter, CDN-S9
CDN-S15, 15-pin Sub-D, 150 kHz - 230 MHz	Calibration adapter, CDN-S15
CDN-S25, 25-pin Sub-D, 150 kHz - 230 MHz	Calibration adapter, CDN-S25
CDN-USB-C, EUT: USB-B, AE: USB-A, 150 kHz - 230 MHz	CDN-USB-C-10k, EUT: USB-B, AE: USB-A, 10 kHz - 230 MHz
Calibration adapter, CDN-USB-C	CDN-USB-P, EUT: USB-A, AE: USB-B, 150 kHz - 230 MHz
CDN-USB-P-10k, EUT: USB-A, AE: USB-B, 10 kHz - 230 MHz	Calibration adapter, CDN-USB-P, as well for USB-3.0
CDN-USB-3.0, EUT: USB-A, AE: USB-A, 150 kHz - 230 MHz	CDN-RJ45-S, shielded RJ45, 150 kHz - 230 MHz
CDN-RJ45-S-10k, shielded RJ45, 10 kHz - 230 MHz	Calibration adapter, CDN-RJ45-S
CDN-Firewire, 6 pole IEEE 1394 receptacle, 150 kHz - 230 MHz	Calibration adapter, CDN-Firewire
CDN-HDMI, 19-pole HDMI 1.3 receptacle, 150 kHz - 230 MHz	Calibration adapter, CDN-HDMI
Mounting bracket for calibration adapter incl. 50/150 Ohm adapter and 50 Ohm termination	Device for direct injection; 100 Ohm; alligator clip; calibration adapter included





Description

For coupling and decoupling disturbing signals to an unshielded cable with balanced lines, T-type CDNs shall be used.

Type	CDN-T2/4/8	CDN-RJ11/RJ45
RF-in		
Frequency range (RF In)	(10 kHz) 150 kHz – 80 MHz / 230 MHz	
Power Rating (RF In)	6 W (continuous)	
Decoupling attenuation (RF In – AE)	> 20 dB (150 kHz – 230 MHz)	
Insertion loss (RF In – EUT)	10 dB ± 1 dB (150 kHz – 230 MHz)	
Connector	BNC	
EUT / AE		
Maximum Input Voltage AC	100 V	
Maximum Input Voltage DC	150 V	
Current Rating (AE – EUT)	0.5 A	
Insertion loss (AE – EUT)	< 1 dB (DC – 1 MHz)	< 1 dB (DC – 10 MHz)
	< 10 dB (1 MHz – 100 MHz)	< 10 dB (10 MHz – 100 MHz)
Connectors	Terminal block	RJ11 / RJ45 jack
Mechanical Data		
Dimensions (B x H x T)	160mm x 84.5mm x 240mm	

Ordering Informations

CDN-T2, terminal block 2 pole, 150 kHz – 230 MHz	CDN-T2-10k, terminal block 2 pole, 10 kHz – 80 MHz
Calibration adapter, CDN-T2 / -AF2	CDN-T4, terminal block 4 pole, 150 kHz – 230 MHz
CDN-T4-10k, terminal block 2 pole, 10 kHz – 80 MHz	Calibration adapter, CDN-T4 / -AF4
CDN-T8, RJ45 jack 8 pole, 150 kHz – 230 MHz	Calibration adapter, CDN-RJ11
CDN-RJ45, RJ45 jack, 150 kHz – 230 MHz	Calibration adapter, CDN-RJ45 / -T8

Mounting bracket for calibration adapter incl. 50/150 Ohm adapter and 50 Ohm termination

COUPLING / DECOUPLING NETWORKS – CDN-CAN-L5 / CDN-CAN-L4

acc. to IEC/EN 61000-4-6

Type	CDN-CAN-L5	CDN-CAN-L4
RF-in		
Frequency range (RF In)	150 kHz – 230 MHz	
Power Rating (RF In)	6 W (continuous)	
Decoupling attenuation (RF In – AE)	PIN 2+7: > 35 dB (150 kHz – 230 MHz) PIN 3+6+9: > 35 dB (150 kHz – 200 MHz); > 25 dB (200 MHz – 230 MHz)	PIN 2+7: > 35 dB (150 kHz – 230 MHz) PIN 3+9: > 35 dB (150 kHz – 200 MHz); > 25 dB (200 MHz – 230 MHz)
Insertion loss (RF In – EUT)	10 dB ± 1 dB (150 kHz – 230 MHz)	
Connector	BNC	
EUT / AE		
Maximum Input Voltage AC	50 V	
Maximum Input Voltage DC	50 V	
Current Rating (AE – EUT)	PIN 2+7 = 0.5 A; PIN 3+6+9 = 3 A	PIN 2+7 = 0.5 A; PIN 3+9 = 3 A
Insertion loss (AE – EUT)	PIN 2+7: < 1 dB (DC – 10 MHz); < 10 dB (10 MHz – 500 MHz) PIN 3+6+9: < 1 dB (DC – 100 kHz)	PIN 2+7: < 1 dB (DC – 10 MHz); < 10 dB (10 MHz – 500 MHz) PIN 3+9: < 1 dB (DC – 100 kHz)
Connectors	9-pol SUB-D socket	
Mechanical Data		
Dimensions (B x H x T)	160mm x 84.5mm x 240 mm	

Ordering Informations

CDN-CAN-L5, 9-pol Sub-D socket, 150 kHz – 230 MHz

Calibration adapter, CDN-AF8-Sub-D, CDN-CAN-L5

CDN-CAN-L4, 9-pol Sub-D socket, 150 kHz – 230 MHz





Features

- EM-clamp for immunity testing of cables with up to 20 mm diameter
- High coupling factor: less than 15 watts amplifier output power is required to obtain a test level of 10 V
- Calibration unit and calibration data are supplied with each instrument

Description

According to IEC/EN 61000-4-6 the preferred coupling and decoupling devices are the CDNs, for reasons of test reproducibility and protection of the AE. However, if they are not suitable or available, clamp injection should be used.

Often, clamp injection needs to be applied to multi-pair balanced cables because suitable CDNs might not be available.

The EM clamp establishes both capacitive and inductive coupling to the cable connected to the EUT.

The EM clamp (in contrast to the conventional current injection clamp) has a directivity ≥ 10 dB, above 10 MHz, so that a defined impedance between the common-mode point of the AE and the ground reference plane is no longer required. Above 10 MHz, the behavior of the EM clamp is similar to that of a CDN.

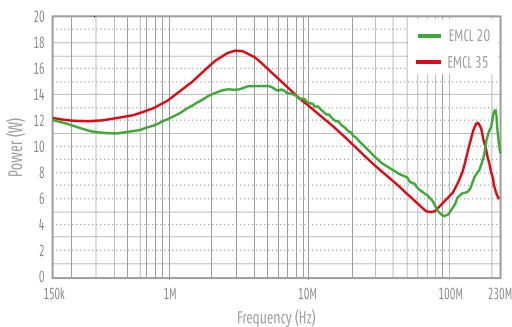

Measured amplifier output power to obtain a test level of 10 V. 6 dB attenuator and 80% amplitude modulation depth are taken into account.



Calibration unit of EMCL (included as standard)

Technical Specifications	EMCL-20	EMCL-35
Frequency range	10 kHz-1000MHz	10kHz-1000MHz
Nominal impedance	50Ω	50Ω
Connector	N-type female	N-type female
Maximum input level		
0.15MHz-100MHz	100W, 15 min.	100W, 15 min.
100MHz-230MHz	100W, 5min.	100W, 5min.
230MHz-1000MHz	50W, 3 min.	50W, 3 min.
Cable diameter	<20mm	<37
Weight	7 kg	14 kg
Dimension (LxWxD)	655 x 120 x 80mm	666x135x120mm

EM DECOUPLING CLAMP – ABCL-20

acc. to IEC/EN 61000-4-6, ED.4



Decoupling clamp for immunity testing cables up to 20 mm diameter

Description

The ABCL-20 is recommended as an additional decoupling network (ferrite tube clamp) for immunity test according to IEC / EN 61000-4-6 when using the clamp injection method. It shall be used on all cables between EUT and AE except the cable under test. The ABCL-20 prevents that the test signal applied to the EUT affects other devices, equipment or systems, which are under test and improve the reproducibility of the test results.

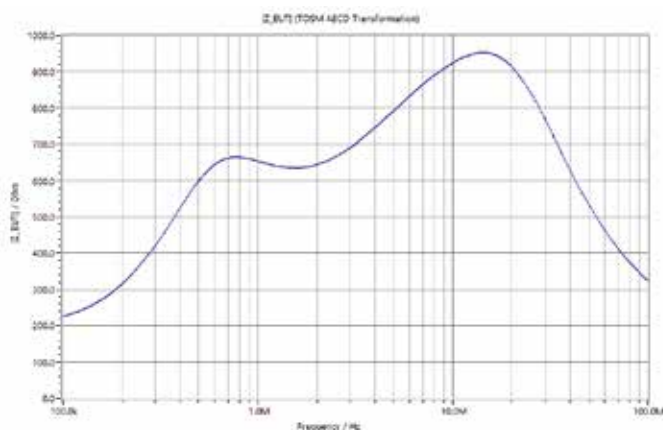
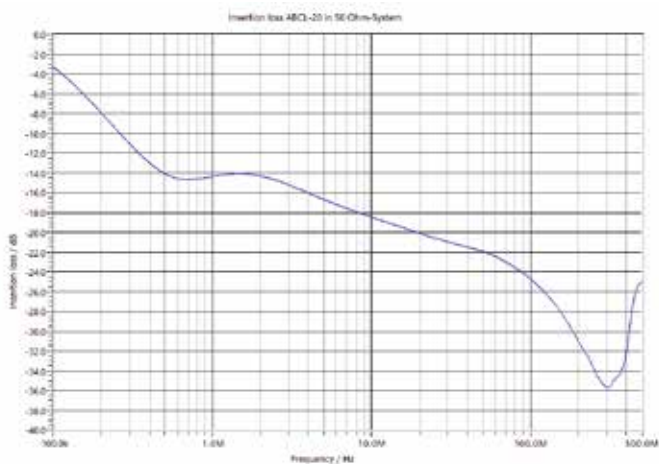

Technical Specifications

Frequency range	100 kHz – 1000 MHz
Max. diameter of cable	<20 mm
Measurement (L x W x H)	632 mm x 120 mm x 80 mm
Weight	7 kg

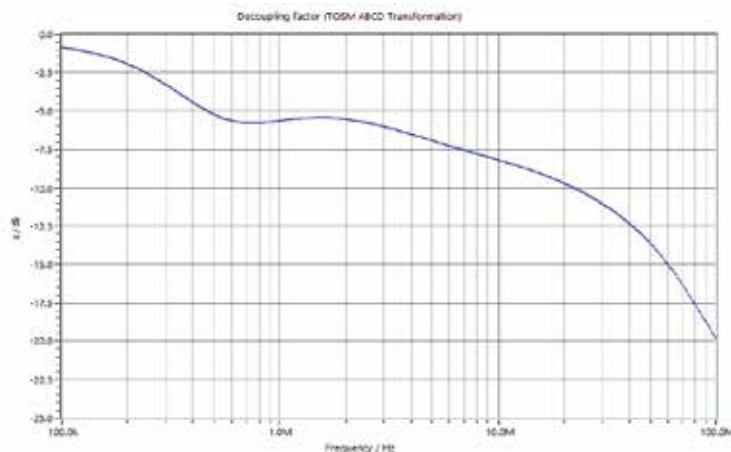

BULK CURRENT INJECTION PROBE – BCI PROBE

acc. to ISO 11452-4, MIL-STD 461 CS 114



(Optional matching transformer)



Bulk current injection probe

The Bulk Current Injection Probe is used to inject RF-current into cables of electrical equipment to test the susceptibility against radiated electromagnetic energy.

It was designed to meet the specifications of ISO 11452-4:2005 and IEC 61000-4-6 standards for automotive BCI testing with secondary currents of 300 mA and more.

The probe can be easily clamped around test conductors and supports cable harness diameters up to 40 mm diameter.

Technical Specifications

Frequency range	4 kHz – 400 MHz
Input Connector	Type N Female
Inner diameter	120 mm
Outer Diameter	40 mm
Width	40 mm
Max. core temperature	90 °C
Turns Ratio	1:1
Primary inductance	5.1 μ H @ 100 kHz
Ambient temperature	0 to 40 °C
Fastening	1 Clip
Input Power rating until core temperature is 90 °C*	90 min @ 70 W (48.45 dBm) 45 min @ 100 W (50 dBm)

* higher input power possible for shorter duration. Control via integrated temperature sensor

Measurement uncertainty: $\pm 0,5$ dB

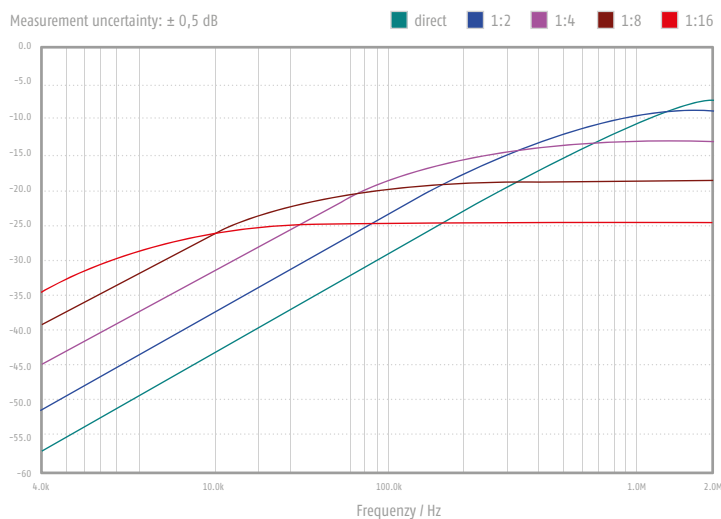

Insertion loss when using the matching transformer MT-1. The selection of the ratio in dependence of the frequency can be optimized by automatic software control via LAN or UB-interface.

Features

- Meets specifications of ISO 11452-4:2005 and IEC 61000-4-6
- Frequency range from 4 kHz up to 400 MHz
- Designed for automotive BCI testing
- Low insertion loss with optional matching transformer

BULK CURRENT MONITORING PROBE – MP50

acc. to ISO 11452-4, MIL-STD 461 CS 114

Current monitoring probe – MP50

The Current Monitoring probes may be used whenever RF current measurements are required. Current measurements are made by placing a current carrying conductor within the "sensing" window of the probe and measuring the probe's output voltage with an RF detector. Calibration of the probe permits the conversion of the voltages measured to current. Current measurements can be made over the frequency range shown in the transfer impedance curve furnished with each probe. There is virtually no loading of the

circuit and the technique permits normal operation of the device under test during measurements.

The MP-50 can be used for the procedure for clamp injection when the common-mode impedance requirements cannot be met given in chapter 7.4 of IEC/EN 61000-4-6 „Immunity to conducted disturbances, induced by radio frequency fields“. The MP-50 can also be used as current monitor for BCI testing as per ISO11452-4, RTCA/DO-160 section 20, MIL-STD-461 and various automotive standards.

Technical Specifications

Frequency range	10 kHz – 400 MHz
Insertion impedance	< 2,5 Ohm
Cable diameter	< 46 mm
Signal output	BNC socket
Max signal current (10 kHz–400 MHz)	1A
Dimensions	Outer diameter 115 mm
	Thickness 30mm
	Overall length 136mm
Weight	0,55 kg

Features

- As required in IEC/EN 61000-4-6
- Suitable for BCI testing per ISO11452-4, RTCA/DO-160 section 20, MIL-STD 461 CS 114, and various automotive standards
- Individual calibration data with each probe



Helia software

The Helia software operates the CIT-1000 for conducted immunity tests from 4 kHz to 1200 MHz. The Software offers different modules for the calibration, the linearity check and the frequency sweep for the testing. The buttons for the different modules are shown on the right. Additionally, the three units, RF-signal generator, RF-power amplifier and RF-voltmeter can also be used separately. The computer-aided control of the CIT-1000 allows modifications according to standards like frequency range, impedance or level without having to manipulate the hardware.

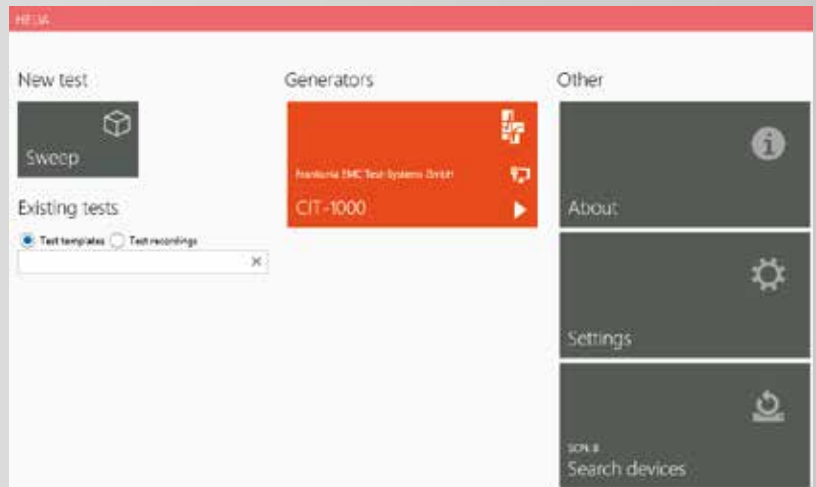

Calibration

The CDNs (Coupling/Decoupling Networks) functionality is to inject a test-voltage into the lines and/or to decouple any connected peripheral equipment from the EUT. As the characteristics of the CDNs and the power amplifier are not linear for every frequency, a calibration is needed. During the calibration the required power to generate a constant test voltage for every frequency is determined. To run the calibration the software needs a start and stop Frequency and a Step increase. According to the used coupling device the impedance, Voltage and Level has to be set as well. Different measured quantities for monitoring, like target or forward power are available on the left panel side. They can be selected and moved to the main window via drag and drop. The calibration can be started with a simple play button in the middle.

Linearity Check

After the calibration a linearity check has to be done to confirm whether the amplifier works in the linear range. The tolerance and the gain can be adjusted according to the standard. With the start of the linearity check two curves are added in the forward power graph. A green line represents the maximum and a rose line represents the minimum of the acceptable values. Both curves result from the measured forward power during the calibration, the gain and the tolerance.



CONTROL SOFTWARE – HELIA

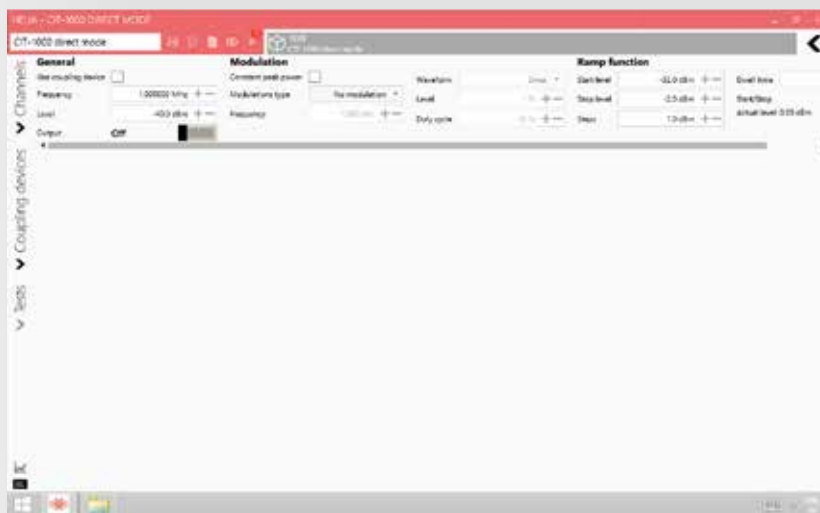

Direct Mode

The direct mode offers the possibility of testing the EUT at discrete frequencies. Either with a fixed test voltage or, optionally, with a ramp function. In that case, the start/stop voltage and the step width needs to be defined by the tester.

After the test, the protocol can be saved. It consists of a diagram which shows the test results and the head of the protocol. The head contains date and time of the test as well as all settings. It can also contain parameters like temperature, air humidity, testing set-up, EUT and name of the person who performed the test.

Sweep

After a successful calibration, a complete test can be started by choosing "Sweep" in the main menu. The settings, e.g. start and stop frequency, step increase and test voltage can be set as in the calibration before. It is possible to change those settings manually. The EUT is monitored automatically and the data are shown graphically, as well as the amplifier output. In case of a malfunction of the EUT, the test can be stopped any time. A description of the malfunction can be entered in a comment line, which is included in the test record.

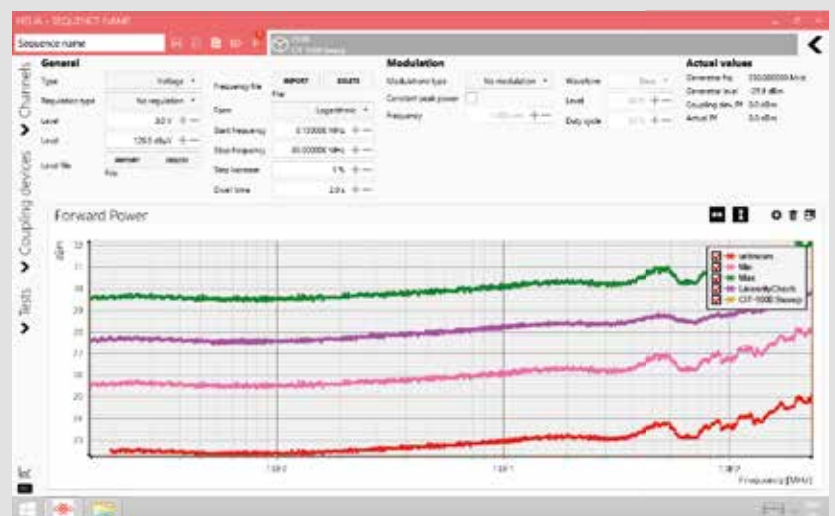



Setup for calibration with EM-clamp acc. to IEC/EN 61000-4-6



Setup for testing with EM-clamp acc. to IEC/EN 61000-4-6



Setup for BCI-calibration acc. to ISO 11452-4, MIL-STD 461 CS114



Setup for BCI-testing acc. to ISO 11452-4, MIL-STD 461 CS114

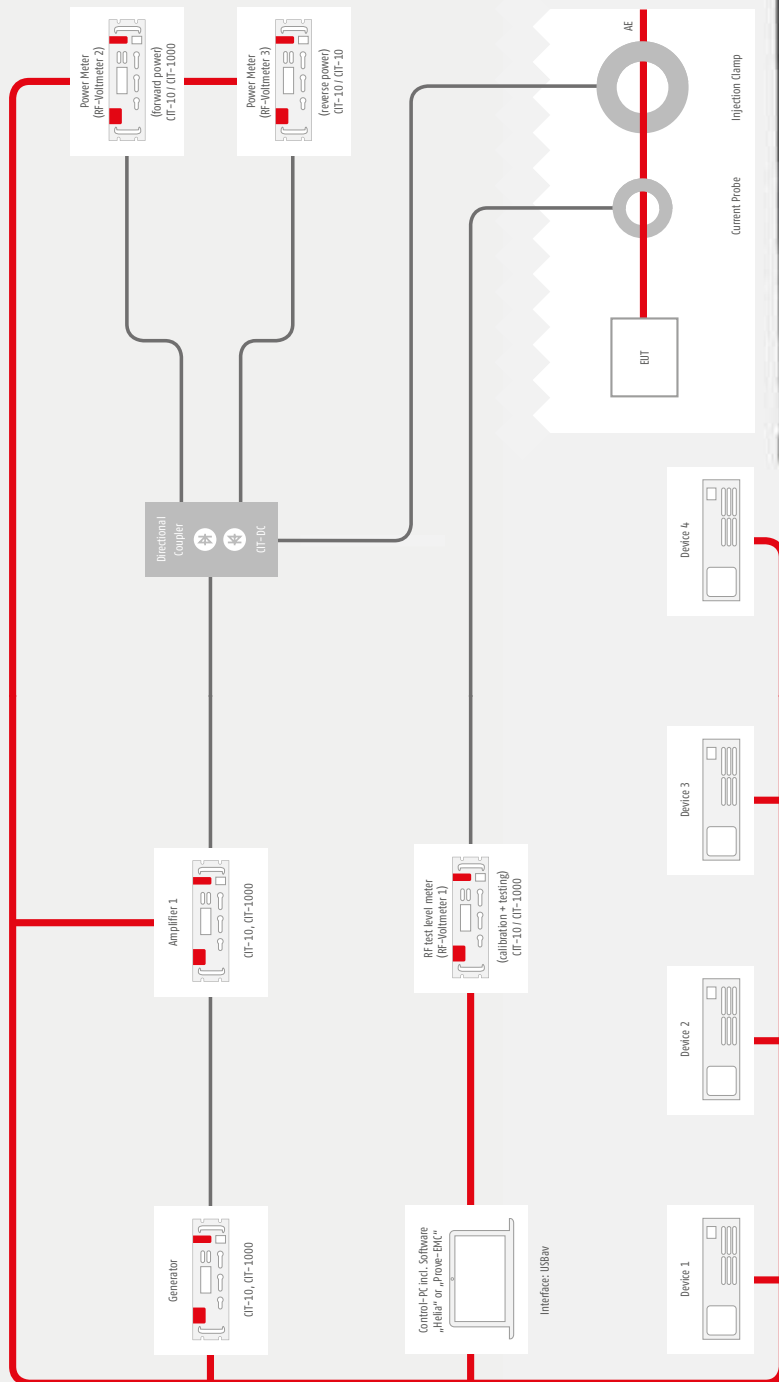



AP-FLYER Sp. z o.o.
Żegańska St.
04-713 Warsaw, POLAND

Phone: +48 22 613 0487
Mail: emc@ap-flyer.pl



www.ap-flyer.pl

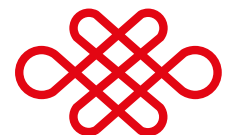

FRANKONIA